FS601 · 603

INSTRUCTIONS

Second edition; issued in June, 1990 第2版(1990年6月発行)

CONTENTS

(FS601·603)

<p>INTRODUCTION..... 2</p> <p>DAILY MAINTENANCE..... 2</p> <p>FOR SAFETY..... 2</p> <p>SPECIFICATIONS..... 2</p> <p>PRECAUTIONS..... 2</p> <p>DRIVING MOTOR PULLEY AND BELTING..... 2</p> <p>MOTOR INSTALLATION..... 3</p> <p>MOTOR SWITCH INSTALLATION..... 3</p> <p>MACHINE INSTALLATION..... 3</p> <p>INSTALLATION DIRECTION OF MACHINE..... 3</p> <p>ADJUSTING POSITION OF MOTOR..... 4</p> <p>FOOT LIFT SHAFT LINK INSTALLATION..... 4</p> <p>FOOT LIFT PEDAL ADJUSTMENT..... 4</p> <p>INTERLOCK AND ADJUSTMENT OF MOTOR CONTROL PEDAL..... 4</p> <p>STOPPER ADJUSTMENT..... 5</p> <p>THREAD TENSION RELEASE ADJUSTMENT..... 5</p> <p>MOTOR COVER INSTALLATION..... 5</p> <p>BELT COVER INSTALLATION..... 5</p> <p>LUBRICATION..... 6</p> <p>THREADING..... 7</p> <p>REGULATING THREAD TENSION..... 8</p> <p>NEEDLE CHANGE..... 8</p> <p>KNIFE CHANGE..... 8</p> <p>SHARPENING KNIVES..... 9</p> <p>REGULATING PRESSER FOOT PRESSURE..... 9</p> <p>PRESSER SHOE CHANGE..... 9</p>	<p>MACHINE ADJUSTMENT</p> <p>TIMING GAUGES (Options).....10</p> <p>DISASSEMBLING.....10</p> <p>NEEDLE POSITION WITH RESPECT TO NEEDLE PLATE FINGER.....11</p> <p>CYLINDER ADJUSTMENT.....11</p> <p>NEEDLE HEIGHT ADJUSTMENT.....11</p> <p>NEEDLE ALIGNMENT.....11</p> <p>LOOPER AVOIDING MOTION ADJUSTMENT.....12</p> <p>LOOPER LEVER AND LOOPER INSTALLATION.....13</p> <p>LOOPER STROKE ADJUSTMENT.....13</p> <p>LOOPER ANGLE ADJUSTMENT.....14</p> <p>LOOPER HEIGHT ADJUSTMENT.....14</p> <p>NEEDLE AND LOOPER STROKE SYNCHRONIZATION.....14</p> <p>ADJUSTING DISTANCE BETWEEN NEEDLE AND LOOPER.....15</p> <p>ADJUSTING CLEARANCE BETWEEN NEEDLE AND LOOPER POINT.....15</p> <p>FEED DOG TILT ADJUSTMENT.....16</p> <p>FEED DOG HEIGHT ADJUSTMENT.....16</p> <p>NEEDLE GUARD ADJUSTMENT.....16</p> <p>NEEDLE THREAD GUARD ADJUSTMENT.....16</p> <p>STITCH LENGTH ADJUSTMENT.....16</p> <p>DIFFERENTIAL FEED RATIO ADJUSTMENT.....17</p> <p>PRESSER FOOT INTERCHANGE.....17</p> <p>CLEARANCE BETWEEN SPREADER AND NEEDLE HOLDER.....18</p> <p>CARRIER AND HOOK ADJUSTMENT.....18</p> <p>NEEDLE THREAD GUIDE (SMALL) ADJUSTMENT.....19</p> <p>NEEDLE THREAD GUIDE (LARGE) ADJUSTMENT.....19</p> <p>PRESSER BAR POST SPRING ADJUSTMENT.....19</p> <p>INSTALLATION POSITION OF SPREADER THREAD GUIDE.....19</p> <p>SPREADER THREAD TAKEUP ADJUSTMENT.....20</p> <p>LOOPER THREAD GUIDE PLATE.....20</p> <p>SETTING LOOPER THREAD EYELETS.....20</p> <p>LOOPER THREAD TAKEUP ADJUSTMENT.....20</p> <p>CLOTH GUIDE ADJUSTMENT (FS603).....21</p> <p>GAUGE PARTS (1).....21</p> <p>GAUGE PARTS (2).....22</p> <p>SPECIFIC PARTS FOR FS603.....23</p>
--	--

INTRODUCTION

This booklet contains some notes on the operation and maintenance of the FS601, which should be useful to you and should help you to become familiar with the machine and to derive the best use from it.

DAILY MAINTENANCE

Before morning start

- (1) Check all Needles are correctly set and not damaged or bent at the tops.
- (2) Check threading is correct.
- (3) Check about 30mm of thread chain remains behind Presser Foot.
- (4) Check the oil jets in Oil Sight Windows are normal. Check oil is maintained at the specified level and the hand-oiled parts are lubricated enough.

After close of work

- (1) Remove dust and lint deposits on the machine.
- (2) If any trouble or disorder is found, report it to the plant mechanic for adjustment or repair.
- (3) Be sure to place Dust Cover over the machine.

FOR SAFETY

- (1) Make sure Belt Cover and Motor Cover are properly fitted.
- (2) Use maximum caution when you connect Power Cord to Machine Motor as well as when you check the machine before switching power on.
- (3) Turn off Motor Switch whenever you leave the work table.
- (4) Turn off Motor Switch in the event of power failure.
- (5) Make sure Motor has completely stopped when attempting to clean, inspect, thread, replace Needles, etc.

SPECIFICATIONS

Machine model : PEGASUS FS601
Stitch type : 607 FSa-1
Stitch length : 10~12 s.p.i.
Standard stitch length : 12 s.p.i.
Maximum speed : 4,200 stitches/min.
Needle : Schmetz 118 GAS
Retainer needle : Schmetz 36211

PRECAUTIONS

- (1) Do not run the machine at more than 3,200s.p.m. for the first 4 weeks.
- (2) Lubricate the moving parts by hand when operating it for the first time or after long shutdown.
- (3) Keep oil level between the two lines on Oil Sight Gauge all the time.
- (4) Change the used oil at the end of the first 4 weeks.
- (5) Perform threading correctly as shown in Treading Diagram on Page 7.

DRIVING MOTOR PULLEY AND BELTING

The machine should use a motor and belt of the following specifications :

- (1) Motor : Clutch motor, 3 phase, 2 pole, 400 watts.
- (2) Belt : V belt, Type M
- (3) Motor pulley : Select an appropriate pulley referring to Table 1.

Table 1

Machine speed (s.p.m.)	Motor pulley outer diameter (mm)	
	60Hz	50Hz
2,900	50	60
3,200	55	65
3,400	60	70
3,600	65	75
3,800	65	80
4,000	70	85
4,200	75	85

MOTOR INSTALLATION (Fig. 1)

Refer to Fig.1 and install ①~③ in sequence on Motor Mount on Pedestal.

- Note that ② should be firmly placed onto Motor.
- Motor Pulley ⑦ with an appropriate outside diameter should be selected by reference to Table 1 on page 2.

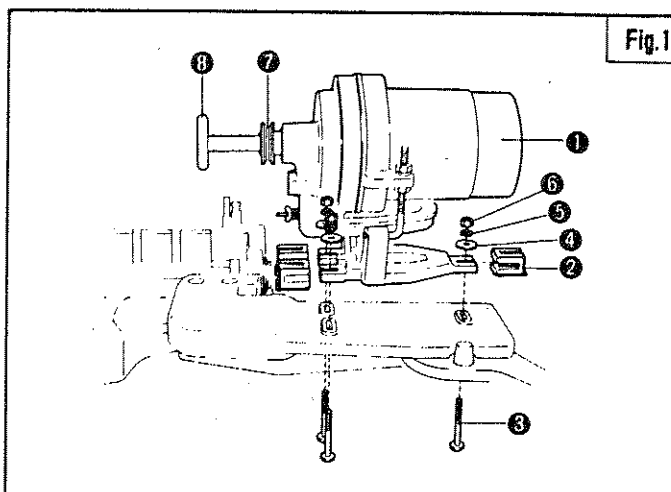

MOTOR SWITCH INSTALLATION (Fig. 2)

Refer to Fig.2 and attach ⑨~⑮ in sequence underneath Motor Mount.

- Be sure to switch power off when installing Motor Switch ⑨.
- After installing Motor Switch, insert the plugs into the power outlet and Motor and check the rotational direction of Motor.
- If Motor runs in the reverse direction, pull the plug ⑮ out of Motor, turn it over and reinsert.

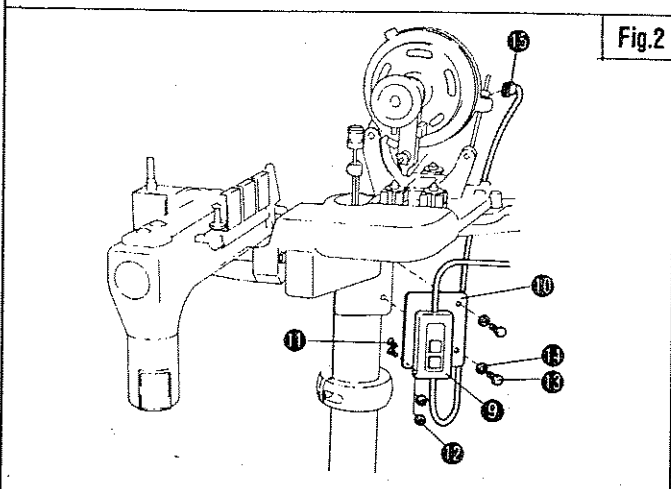

MACHINE INSTALLATION (Fig. 3)

Refer to Fig.3 and fit the machine to Machine Base on Pedestal with Bolt ⑮ and Washer ⑰.

- Bolt ⑮ is used to hold Machine Base.
- Turn the bolt until it touches the rear side of Machine Base and lock it with Nut ⑲ securely enough to withstand machine vibrations.

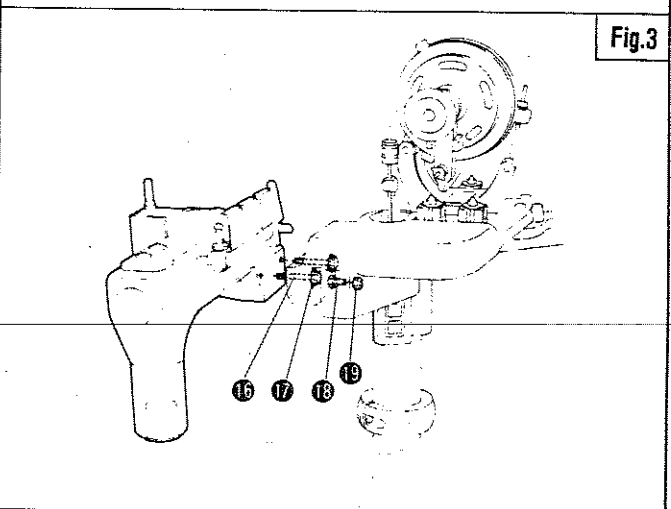

INSTALLATION DIRECTION OF MACHINE (Fig. 4)

Install the machine so that the line (a) on Pedal and the surface (b) of the end of Cylinder are parallel to each other as shown in Fig.4.

To adjust :

- Loosen Screw ⑳ and turn Machine Base ㉑.

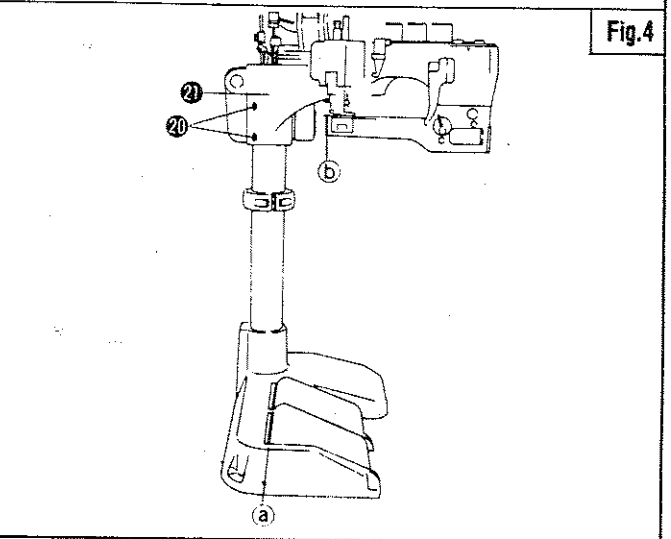

ADJUSTING POSITION OF MOTOR (Fig. 5)

The center of the V-groove on Machine Pulley ① should line up with the center of the V-groove on Motor Pulley ②.

To adjust :

Loosen Nut ③.

• Belt tension should be adjusted in such a way that the flexure of the belt should be about 2 cm when pressed in the middle of Motor Pulley and Machine Pulley.

• To adjust belt tension, Loosen Nut ④ or Nut ⑤.

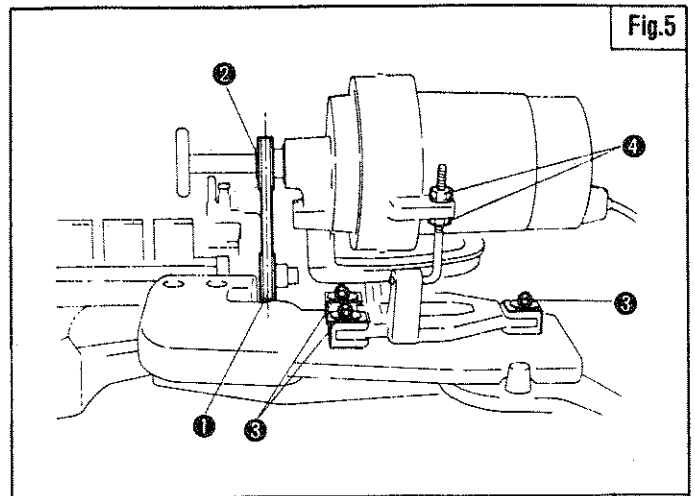

FOOT LIFT SHAFT LINK INSTALLATION (Fig. 6)

Refer to Fig.6 and interlock Pedestal Lever ⑤ to Machine Lever ⑥ with Foot Lift Shaft Link ⑦ and Screw ⑧.

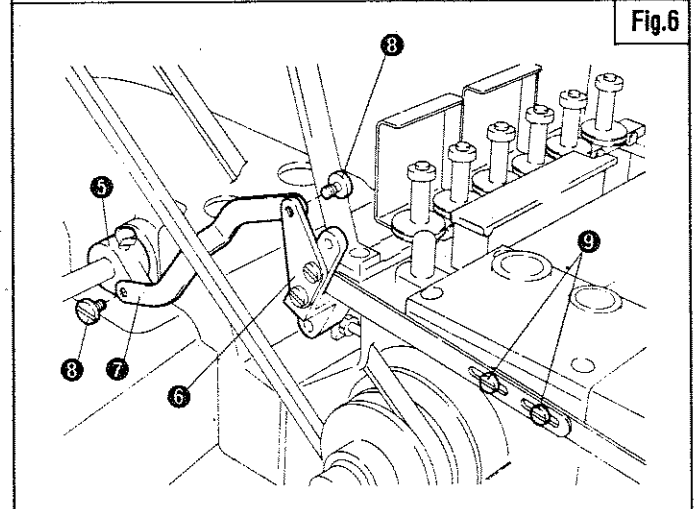

FOOT LIFT PEDAL ADJUSTMENT (Figs. 6-7)

To adjust :

Loosen Screw ⑨ as shown in Fig.6.

• To make this adjustment, lower Presser Foot all the way down and make a clearance of about 1.0mm between ⑩ and ⑪.

If there is no clearance at all, it sometimes happens that Presser Foot cannot move down completely.

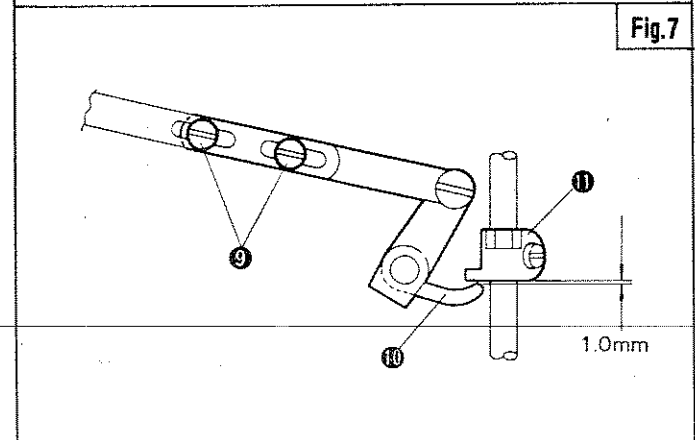

INTERLOCK AND ADJUSTMENT OF MOTOR CONTROL PEDAL (Fig. 8)

Press Pedal backward to raise ⑫, then install ⑬~⑳ in sequence as shown in Fig.8.

• Pressing Pedal forward and backward should cause the machine to start and stop in good timing respectively.

To adjust :

Loosen Screw ㉑.

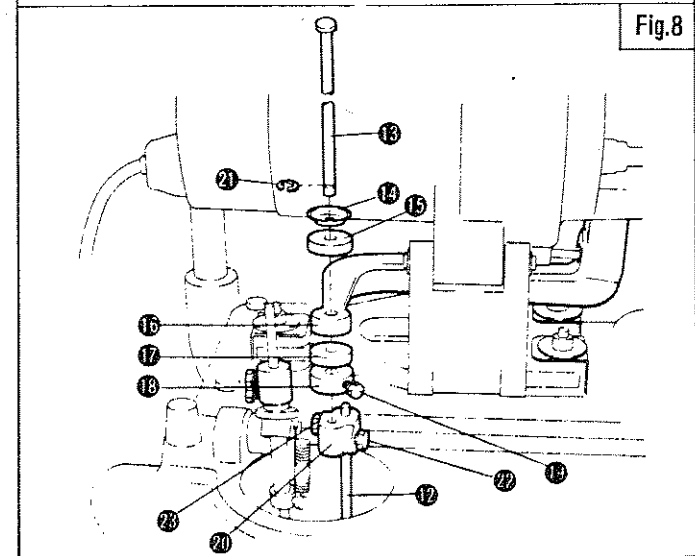

STOPPER ADJUSTMENT (Fig. 9)

Adjust Stopper ② so that Hook of Presser Foot does not hit Needle Holder when Presser Foot Lift Pedal is pressed completely.

To adjust :

Loosen Nut ① and turn ②.

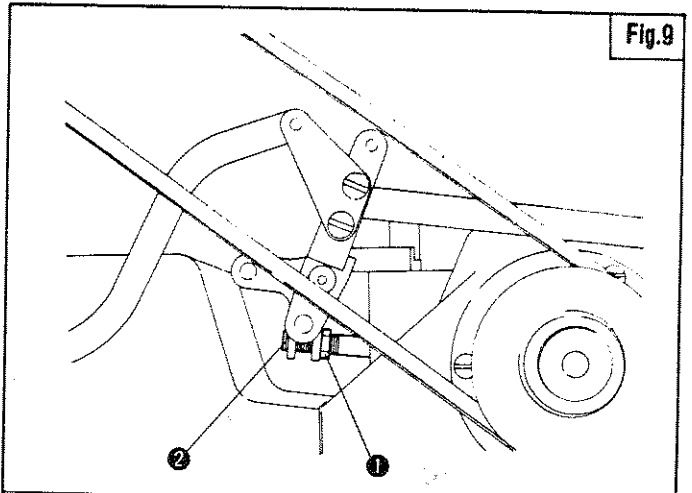

Fig.9

THREAD TENSION RELEASE ADJUSTMENT (Fig.10)

Thread Tension Release Plate should be adjusted so that tension release is effected as soon as Presser Foot Lift Pedal is stepped on to raise Presser Foot.

To adjust :

Loosen Screw ③ and rotate ④.

- Check to see that while Presser Foot is being held down thread tension release is not effected and thus that each thread is kept taut.

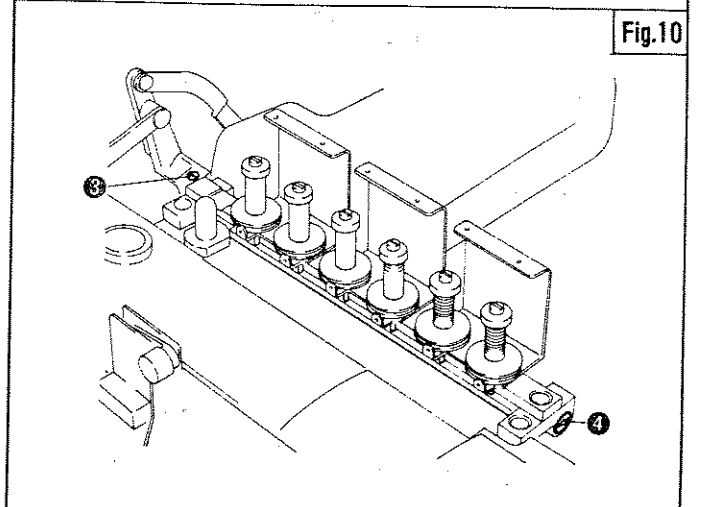

Fig.10

MOTOR COVER INSTALLATION (Fig. 11)

Refer to Fig.11 and fit ⑤~⑦ in sequence.

- Collar ⑥ is used to adjust the height of Motor Cover ⑦.

- When attaching Collar ⑥ to Support Shaft ⑧ of Motor Cover, adjust the height of Motor Cover so that a clearance is made between Pedestal Pin and Support Shaft to prevent vibration.

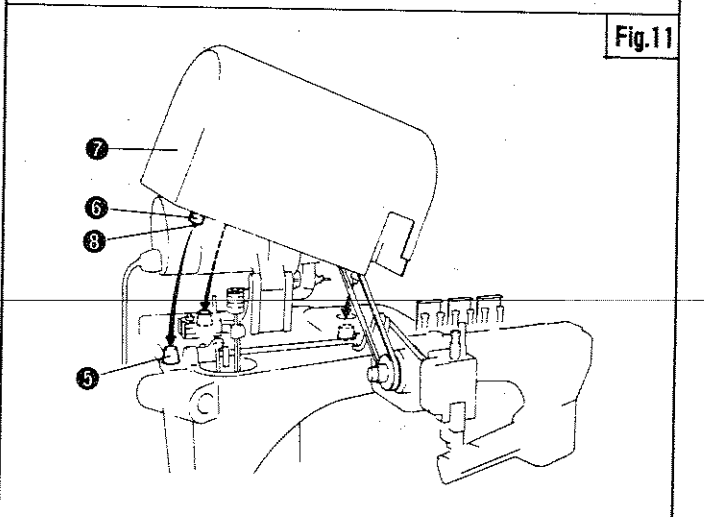

Fig.11

BELT COVER INSTALLATION (Fig. 12)

Refer to Fig.12 and attached Belt Cover ⑨ with Screw ⑩.

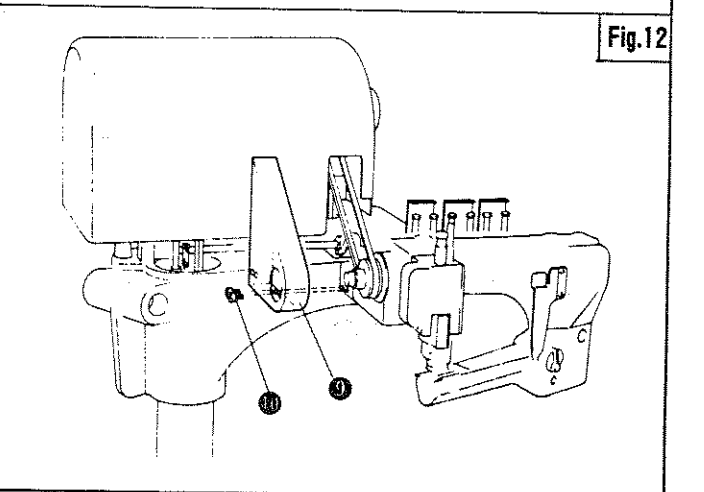

Fig.12

LUBRICATION

1 Type of oil to be used :

Mobil D.T.E26 (Mobil Oil Corporation).

- Viscosity : 64CS at 40°C

2 To fill Oil Reservoir : (Figs. 1 and 2)

Unscrew Plugs 1 and 2 and pour oil into Oil Reservoir until oil level reaches upper line 'H' of Gauges 3 and 4.

3 Oil level (Figs. 13 and 14)

Always keep enough oil in the machine so that oil level is between the two lines 'H' and 'L' on Gauges 3 and 4.

- The two lines on Gauge 'H' and 'L' indicate the maximum and minimum limits of oil level.

4 Additional lubrication (Fig. 13)

On the following occasion, lubricate the moving parts by hand after removing Screw 5 and 6.

- (1) When the machine is used for the first time.
- (2) When the machine is used after a long shutdown.

5 Hand lubrication (Fig. 15)

Apply hand lubrication to the following parts :
Presser Foot Links, Knife Carrier Shank, Needle Bar Bushing, and others.

- Excess oil may stain the fabric. Thus be sure to add a minimum necessary amount of oil.

6 Oil circulation check :

After oiling, run the machine and check to see that the oil jets in Oil Sight Windows 7 and 8 are normal. If not, remove Plugs 5 and 6 and add oil.

7 Oil Change :

- (1) Change all the used oil at the end of the first 4 weeks.
 - (2) Thereafter, change oil every half a year.
- Failure to change oil at regular intervals will substantially reduce the service life of the machine.

8 To drain oil (Figs. 14 and 16)

Remove Plug 9 on the machine bottom and Plug 10 underneath pulley.

- Remove Belt Cover (9 on Page 5) before removing Screw 10.

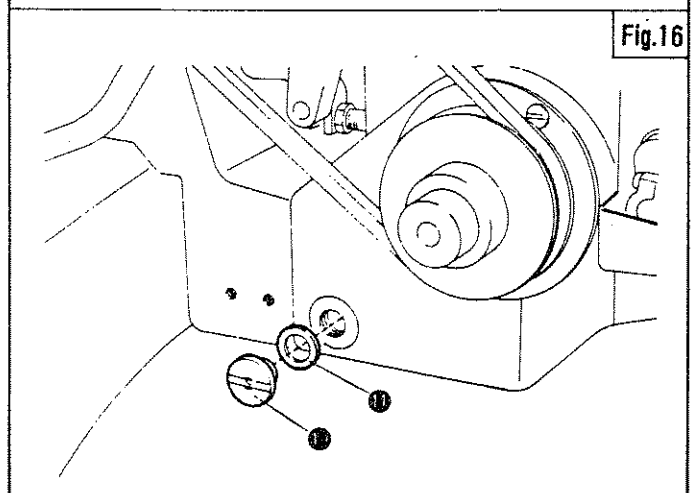
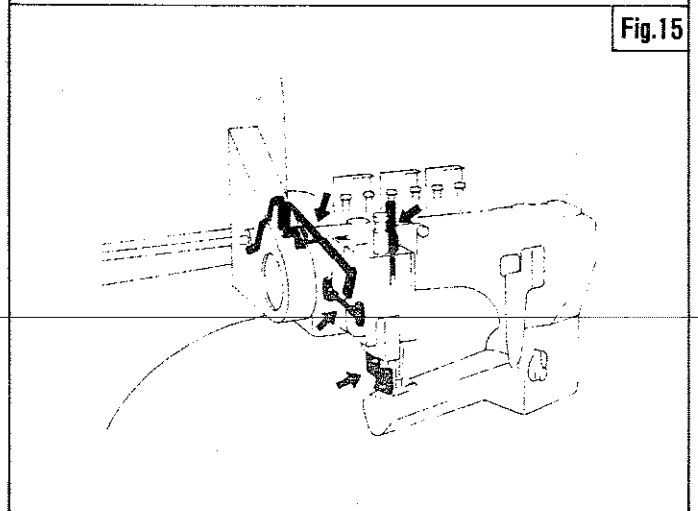
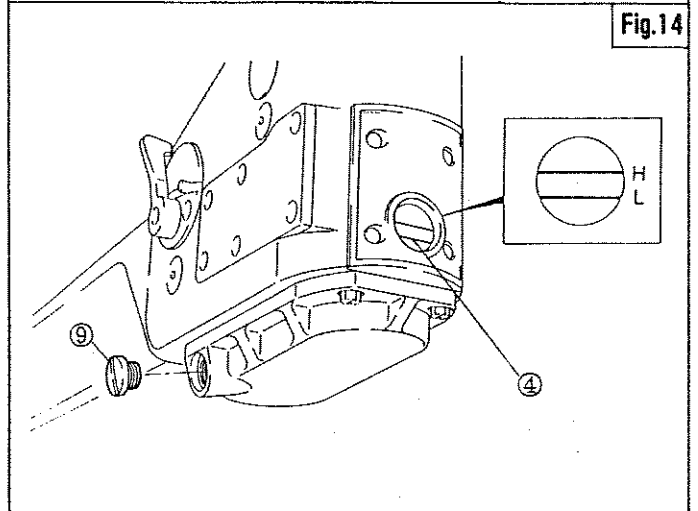
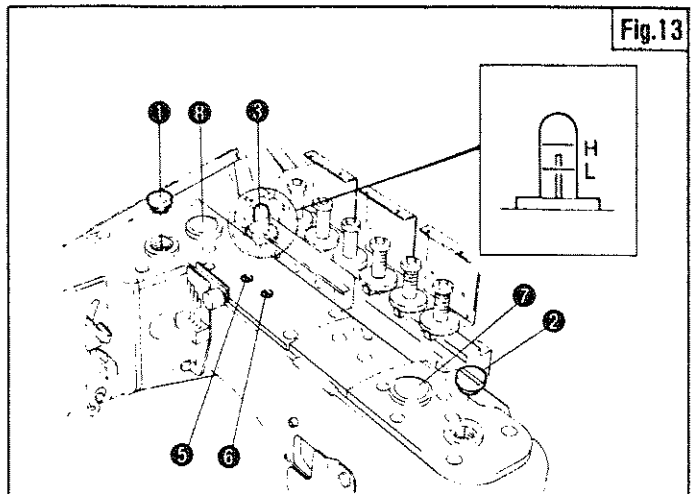

THREADING (Fig. 17)

Fig. 17

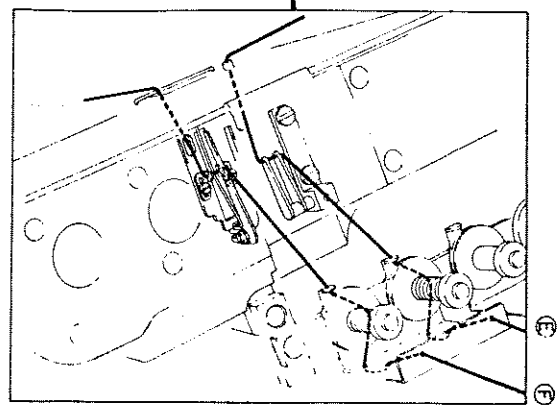
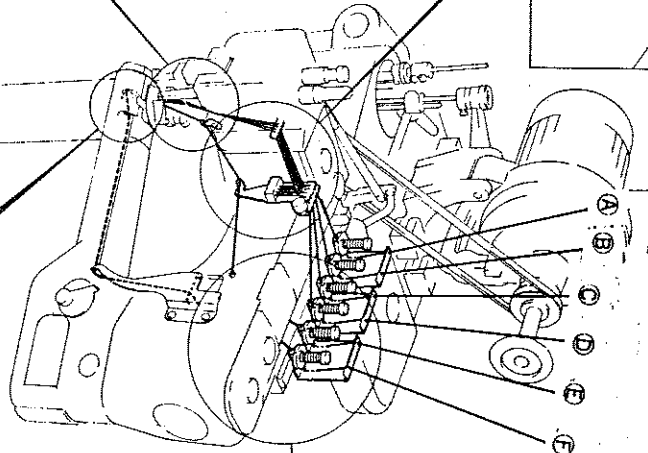
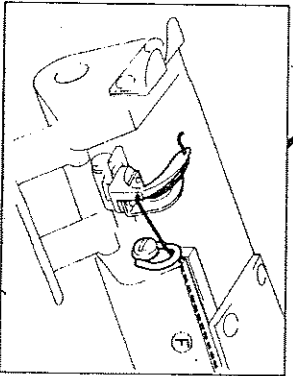
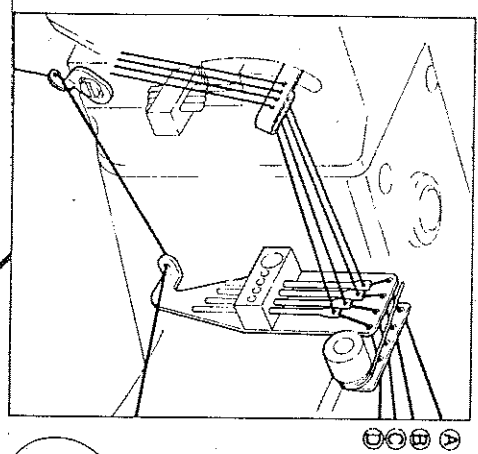
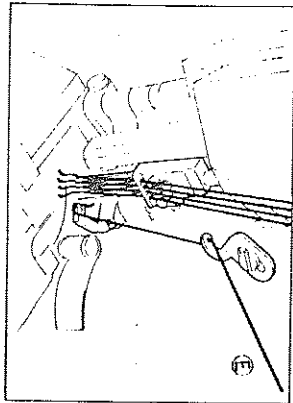

REGULATING THREAD TENSION (Fig. 18)

1 Needle thread

To adjust thread tensions : Turn Nuts ①, ②, ③ and ④.

- Individual thread tensions should in most cases be different from each another. Usually the first needle thread tension ① is higher than any others.

2 Looper thread

To adjust :
Turn Nut ⑤.

- Too much tension on Looper thread tends to disturb both the needle thread and thread chain.

3 Spreader thread

To adjust, turn Nut ⑥.

- Too much tension on the Spreader thread may disturb the first line of stitches.

NEEDLE CHANGE (Fig. 19)

Loose Screw ⑦ and replace the used needle with a new one by reference to Fig.19.

- Schmetz 118GAS should be used.
- Schmetz 36211 should be used as Retainer Needle ⑧.
- All the needles used in the machine have flats. To take out a needle, loosen Screw until Screw tip is free from the flat.
- To attach a needle insert a new needle all the way into the needle holder while holding the needle with the front side facing you, and tighten Screw until Screw tip touches the flat.

KNIFE CHANGE (Fig. 20)

Upper Knife ⑨

To replace :

Loosen Screw ⑩ and raise ⑪ as shown in Fig.20.

- Adjust the overlap of Upper and Lower Knives to 0.5 to 1.0mm when Upper Knife is in the left extreme as shown in Fig.20.
- If necessary to incline Upper Knife to get a better scissor action with Lower Knife, remove ⑭~⑮ in sequence and turn Screw ⑯.
- When replacing, fit Screw ⑰ with the hole in Bracket after making sure that Screw ⑰ does not protrude beyond the sole of Upper Knife Clamp ⑮.

Lower Knife ⑫

To replace :

Loosen Screw ⑬ and raise ⑪.

- Insert Lower Knife until the blade tip ⑱ comes to the middle point between the second and third needles from the left.

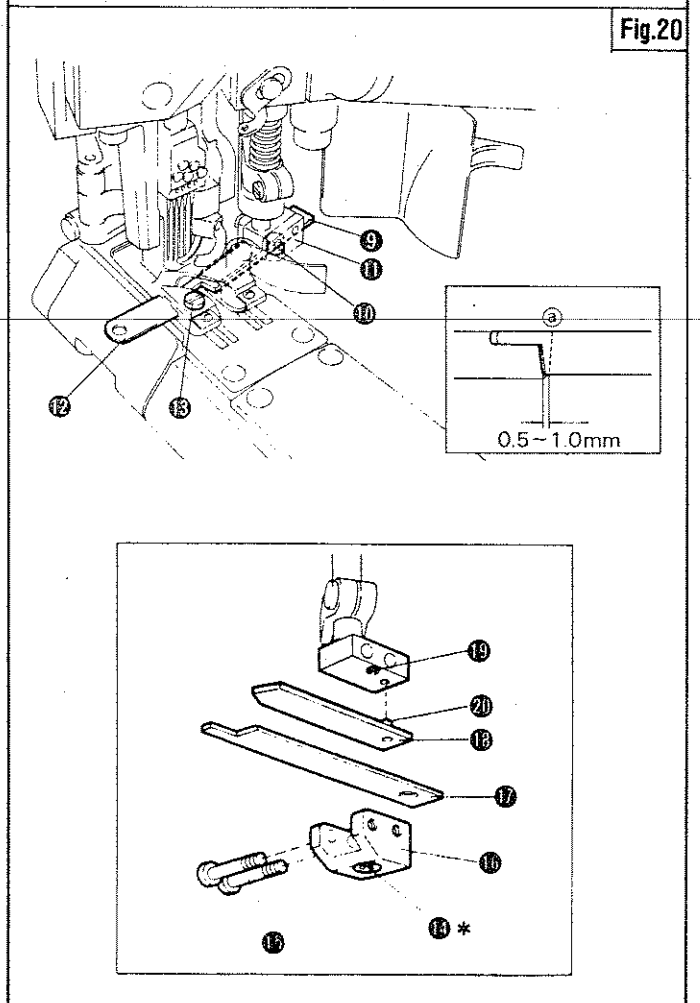
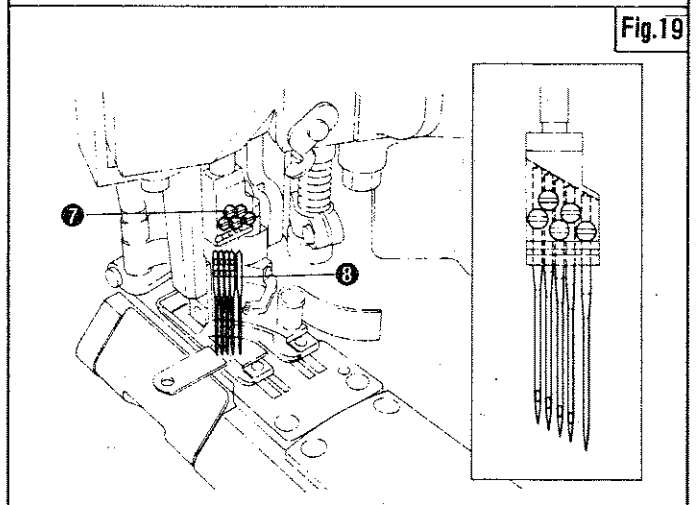
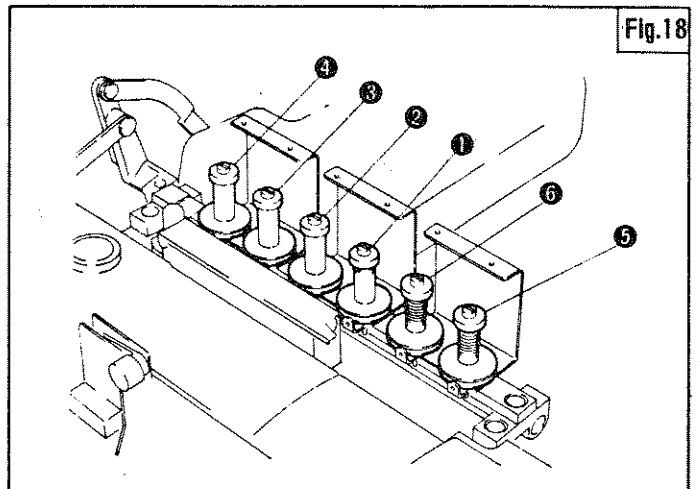

SHARPENING KNIVES (Figs. 21 and 22)

- (1) Refer to Fig.21 for Upper Knife.
 - (2) Refer to Fig.22 for Lower Knife.
- In both Knives Mark \odot indicates the most critical portions that require special care and accuracy.

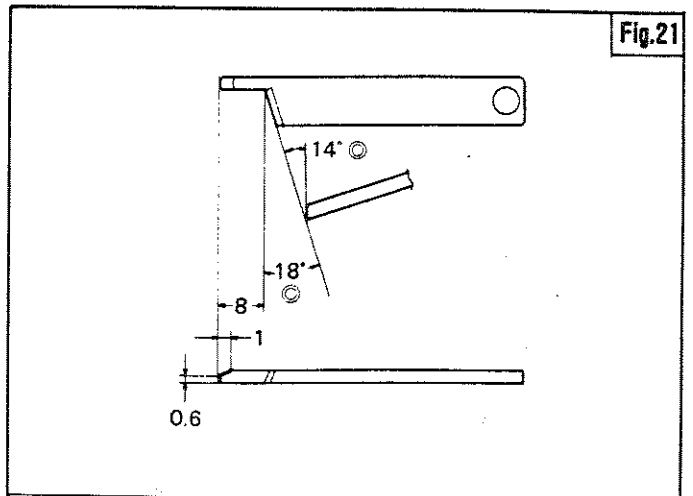

Fig.21

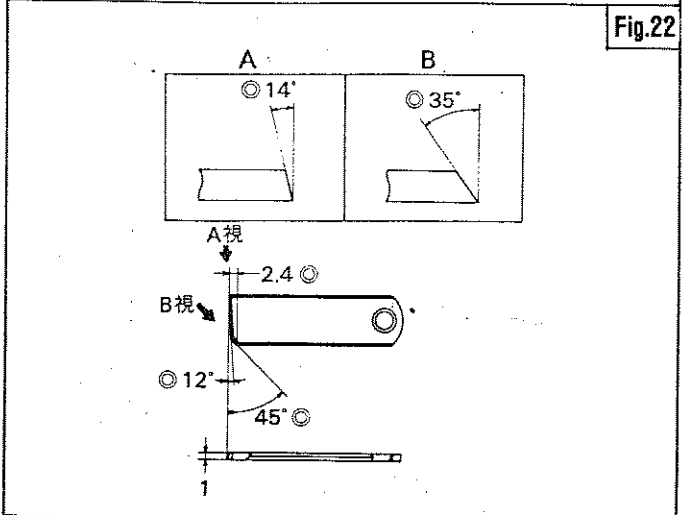

Fig.22

REGULATING PRESSER FOOT PRESSURE (Fig. 23)

To adjust :

Turn Thumb Screw **1**.

- Presser Foot should be operated with a minimum pressure only sufficient to precisely feed the fabric and obtain uniform stitch formation.

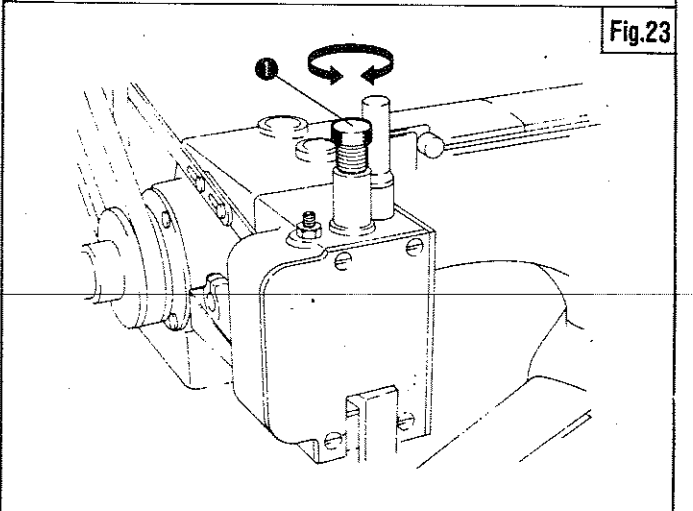

Fig.23

PRESSER SHOE CHANGE (Fig. 24)

Refer to Fig.24 and remove **2**~**9** in sequence. To assemble, fit the parts in the reverse order.

- To replace **7** and **9**, raise Needle Bar to the upper dead point and keep Presser Foot up.

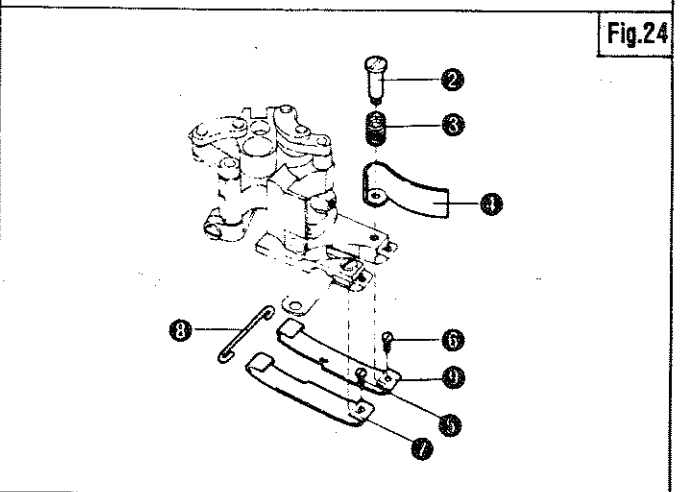

Fig.24

MACHINE ADJUSTMENT

TIMING GAUGES (Options)

Gauges are available as optional tools to help you adjust: various machine timings such as Needle height, Looper stroke, Looper avoiding motion, Looper angle, timing of Looper and Needles, and distance between Needle and Looper. Instructions for using Gauges are given with ■ mark in every section.

DISASSEMBLING (Figs. 25, 26, 27, 28 and 29)

If it is necessary to disassemble the machine and re-adjust machine timings, remove ❶ to ❷ in sequence as shown in Fig.25 to 29.

- Screws with * marks on the reference numbers should not be removed but loosened to such a degree that the parts secured by them are ready to be removed.
- Do not remove Presser Bar ❶ shown in Fig. 27 but raise it to the position where it allows Presser Foot ❷ to be removed.
- When removing the related parts, raise Needle Bar to the upper dead point.

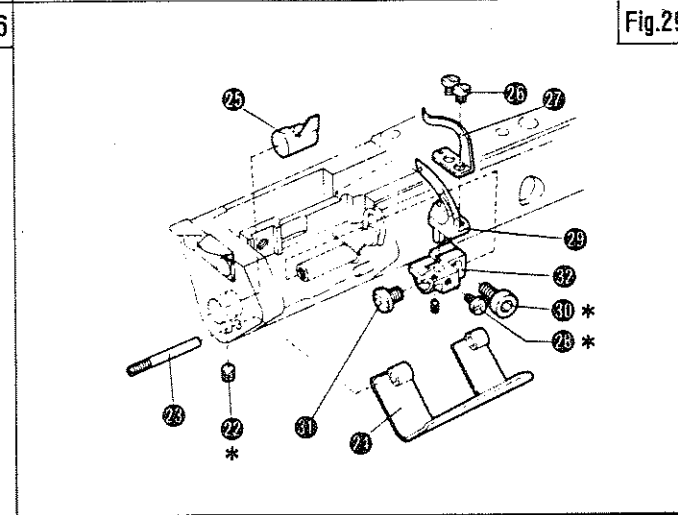
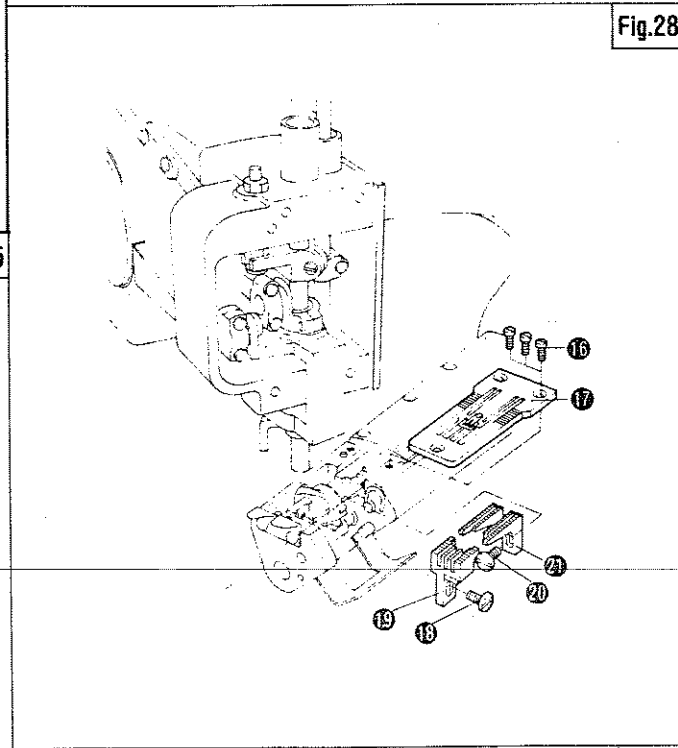
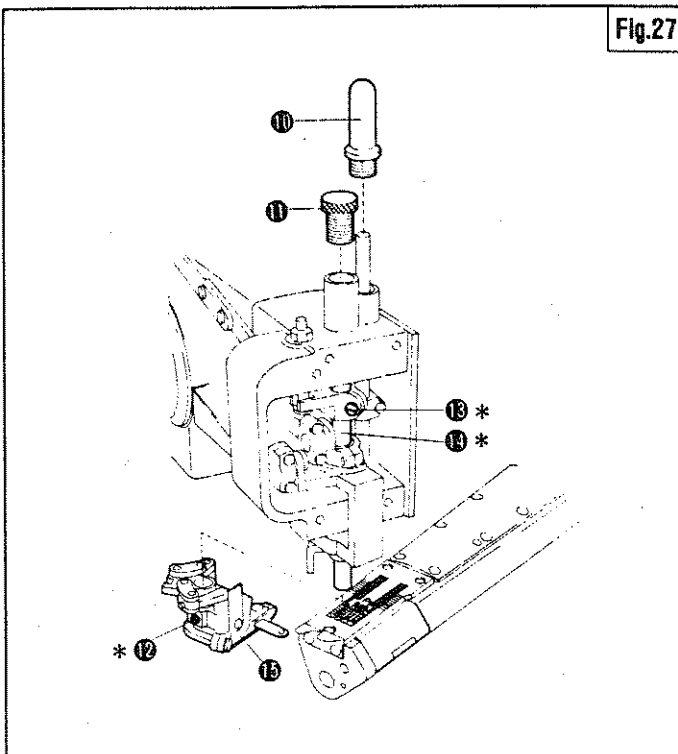
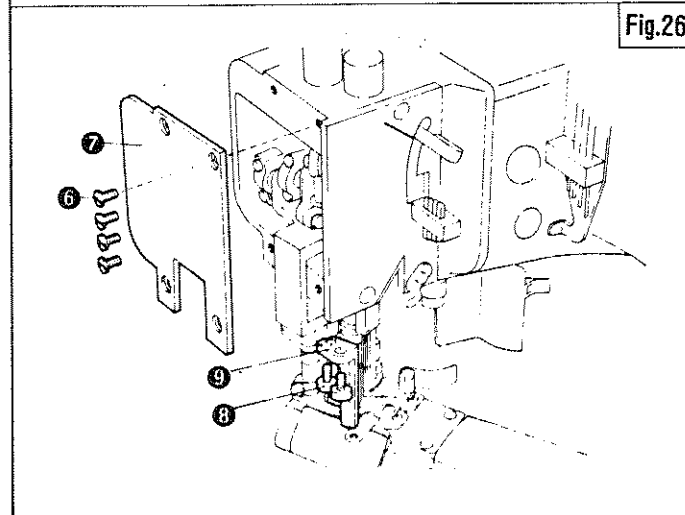
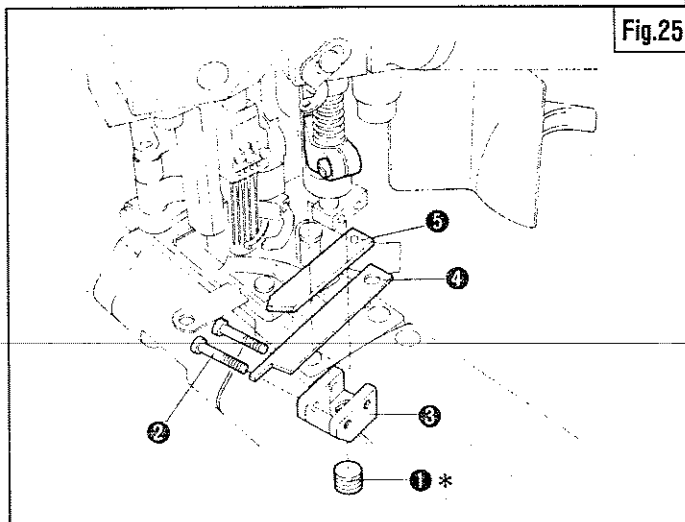

NEEDLE POSITION WITH RESPECT TO NEEDLE PLATE FINGER (Fig. 30)

Install Needle Plate and confirm that the clearance (a) on the left side of the needle is larger than the clearance (b) on the right side by about 0.15mm.

- If the above requirement is not met, make adjustment for Cylinder.

CYLINDER ADJUSTMENT (Fig. 31)

(1) Refer to Fig.31 and remove ①~③ in sequence to take out Cover ②.

(2) To adjust Cylinder, loosen Screws ④ and ⑤ and turn ⑥.

• Turning ⑥ to the right will move Cylinder to the left.

• Turning ⑥ to the left will move Cylinder to the right.

• Keep Cover ② removed until Looper stroke adjustment is completed.

NEEDLE HEIGHT ADJUSTMENT (Fig. 32 and 33)

When Needle Bar is at the upper dead point, the distance between the tip of Left Needle ⑦ and the upper surface of Needle Plate should be 13.3mm.

To adjust, loosen Screw ⑧.

■ For instructions for using Gauge ⑨, refer to Fig.32.

NEEDLE ALIGNMENT (Figs. 33 and 34)

Install the first and forth needles from the left in such a way that the straight line across the needles is at right angles with Needle Plate Slots as shown in Fig.34.

To adjust, loosen Screw ⑧.

■ In the case of using Upper Knife as a gauge, place Upper Knife at right angles with Needle Plate Slots as shown in Fig.34.

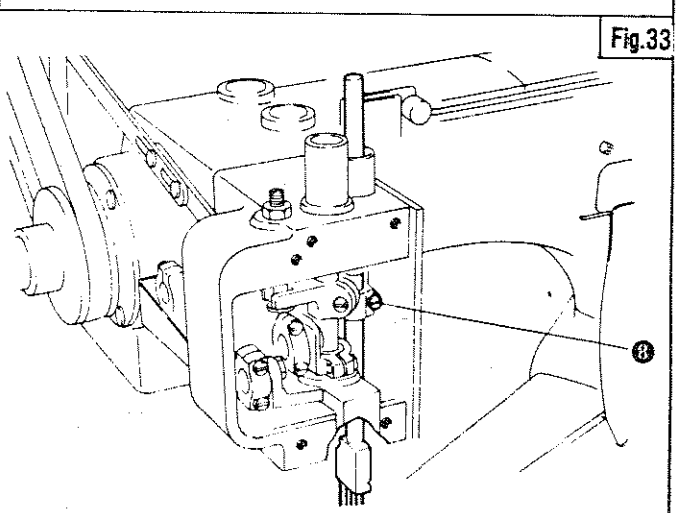
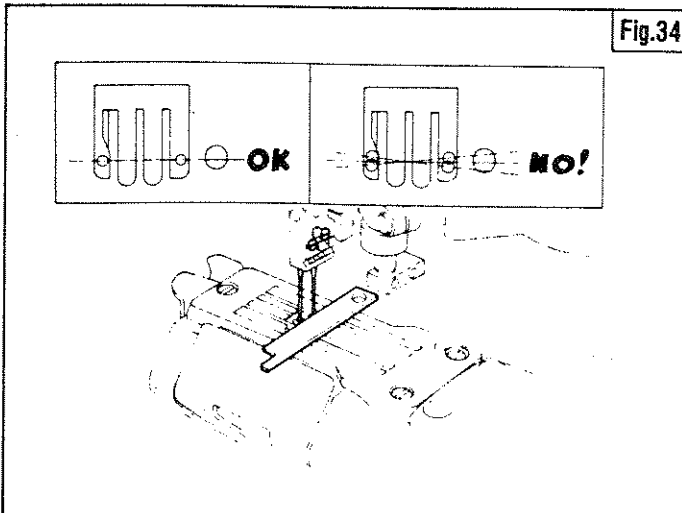
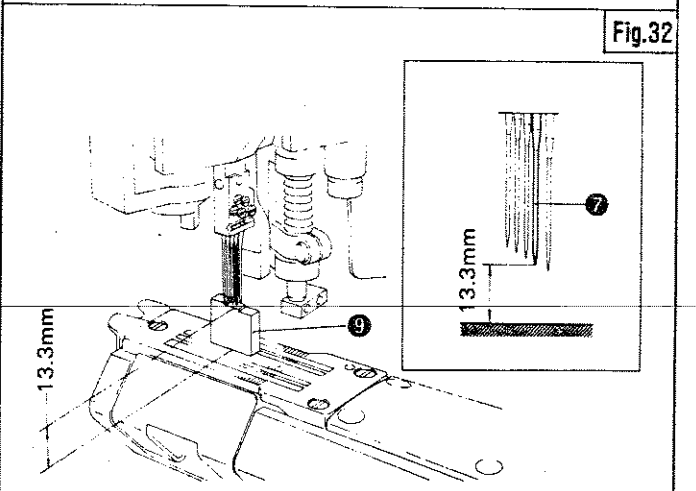
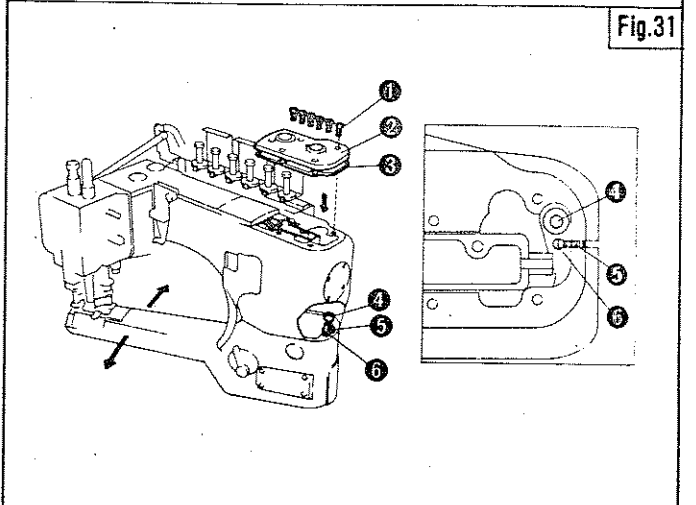
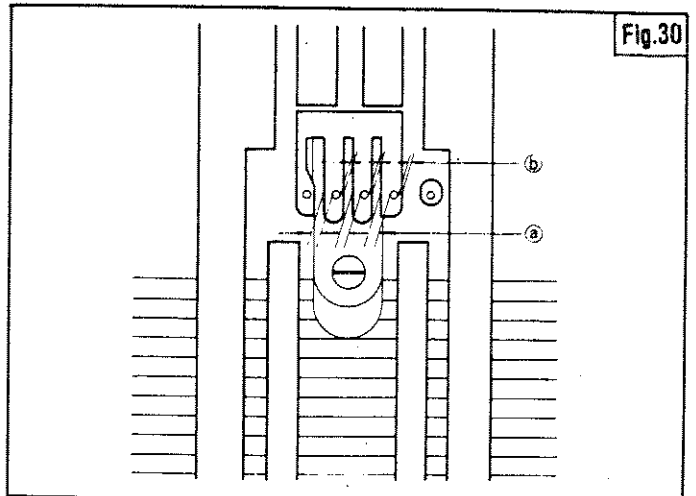

LOOPER AVOIDING MOTION ADJUSTMENT

1 Removing the parts (Fig. 35)

Refer to Fig. 35 and remove ① ~ ③ in sequence.

2 How to measure Looper avoiding motion (Figs. 36 and 37)

With Looper Lever (⑫, Page 10) removed, insert a vernier calipers or a gauge into the void left by removing the bracket from the end of Cylinder so as to measure the avoiding motion of ④.

3 Adjusting Looper avoiding motion (Fig. 38)

Looper avoiding motion should be adjusted to 2.6~2.3mm by loosening Screw ⑧ and then moving Link ⑨ up or down.

- Move ⑨ up to reduce avoiding motion, and move ⑨ down to increase it.

How to use Gauge ⑤ (Figs. 36, 37 and 38)

- (1) Insert Gauge ⑤ such that ⑥ comes out fully when ④ reaches point A (the forward extreme). Then lock Gauge ⑤ with Screw ⑦.
- (2) Locate the face a of Gauge so that it falls within the 0.3mm indentation between the ends b and c of ⑥ when ④ returns to point B.

To adjust :

Loosen Screw ⑧ and move Link ⑨ up or down.

- Moving Link ⑨ up will decrease the Looper avoiding motion, and moving ⑨ down will increase it.

Fig.35

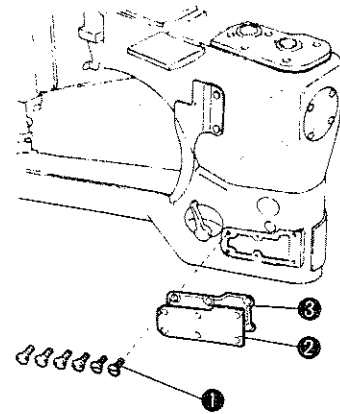

Fig.36

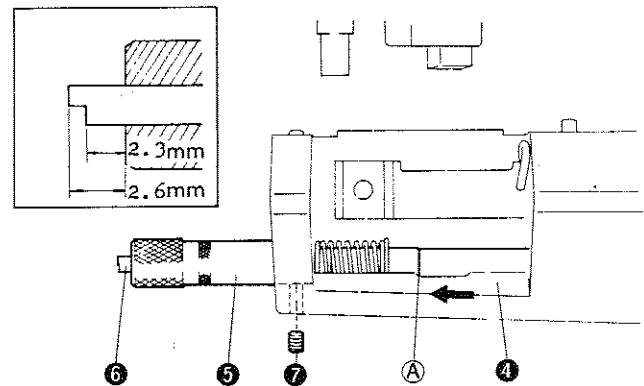

Fig.37

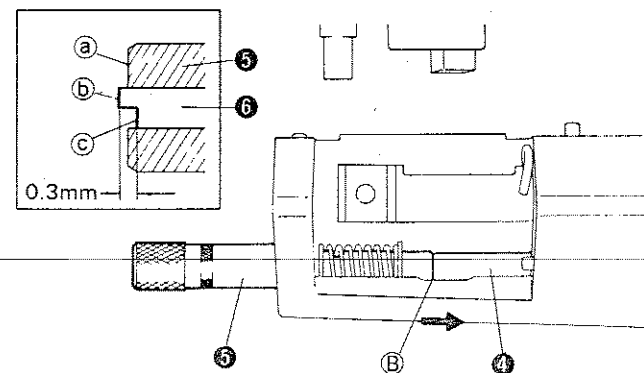
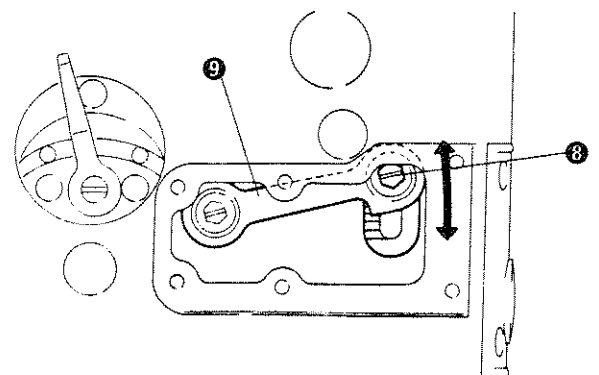
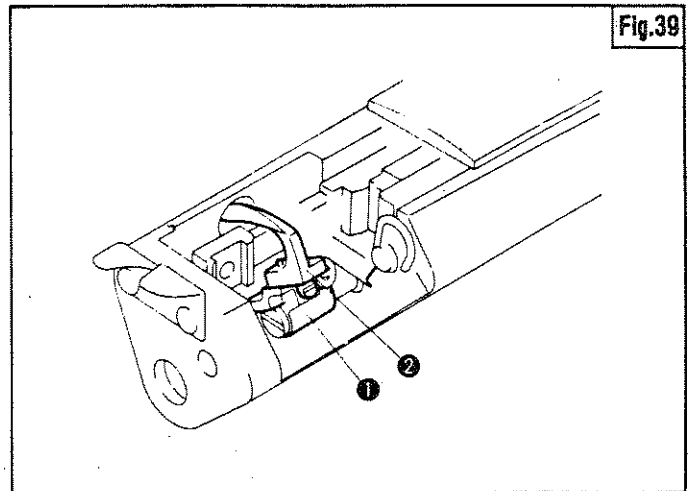

Fig.38



LOOPER LEVER AND LOOPER INSTALLATION(Fig.39)

Refer to Fig.39, and install ① and ②.



LOOPER STROKE ADJUSTMENT(Fig. 40)

Looper stroke should be 25.5mm.

To adjust :

Refer to Fig.40, loosen Nut ③, and turn Screw ④.

Turning Screw ④ to the right will reduce Looper stroke, and turning Screw ④ to the left will increase it.

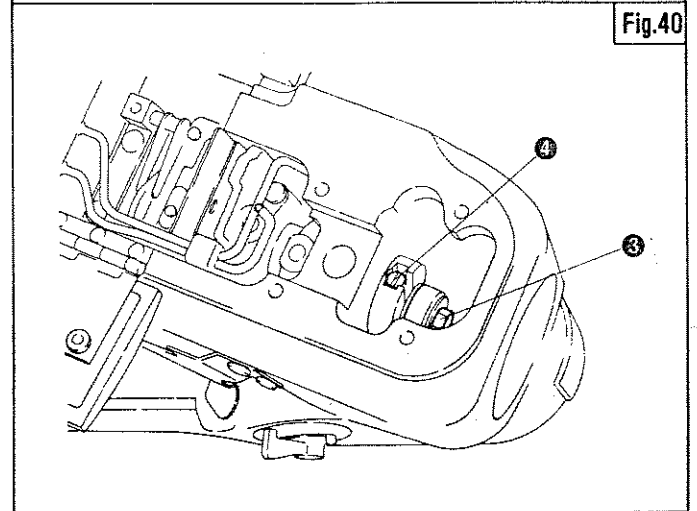

How to use Gauges(Figs. 41 and 42)

- (1) Gauges ⑤ and ⑥ should be used as a pair.
- (2) Refer to Fig.41, insert the hub of Gauge ⑤ into the hole on the end of Cylinder, and tentatively lock Gauge ⑤ with Screw ⑦ while holding the gauge bottom horizontally.
- (3) Install Gauge ⑥ with Needle Guide Screw ⑧.
- (4) Turn the pulley until Looper and Gauge ⑥ come to the right dead point, move Gauge ⑤ so that the "0" graduation lines up with the point of Gauge ⑥, and tighten Screw ⑦.
- (5) Turn the pulley until Looper and Gauge ⑥ come to the left dead point. At this point, ensure that the point of Gauge ⑥ falls within the range from $54^{\circ}40'$ to $56^{\circ}40'$ ($55^{\circ}40'$ standard).
- (6) If the point of Gauge ⑥ fails this range, Looper stroke needs to be adjusted.
To adjust :
Loosen Nut ③ and turn Screw ④ as shown in Fig.40.

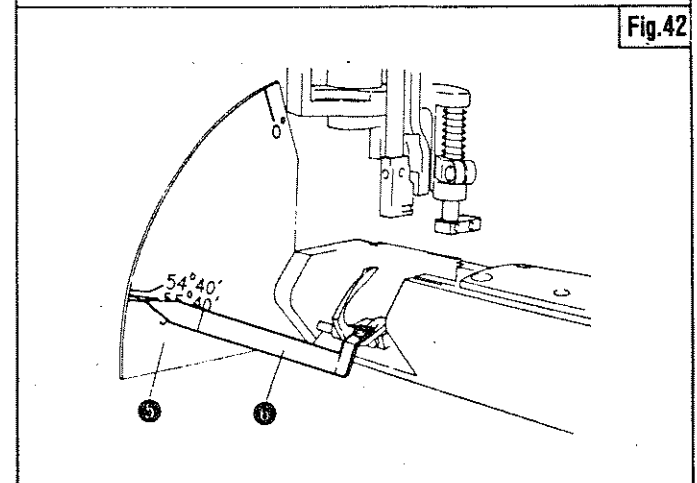
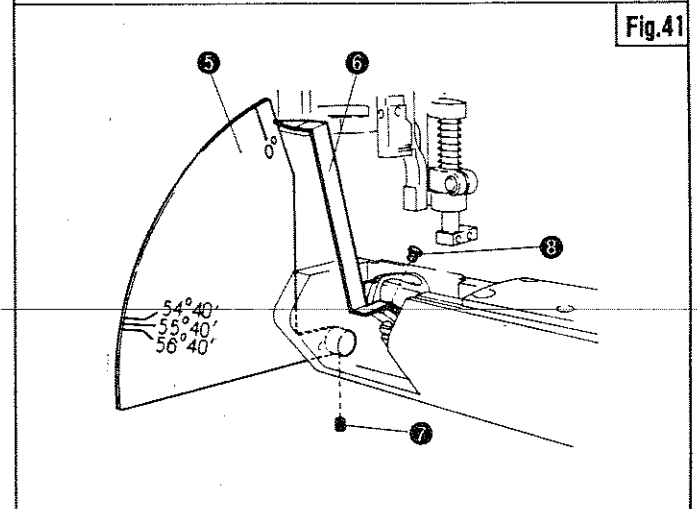

LOOPER ANGLE ADJUSTMENT(Figs. 43 and 44)

Looper should be installed with its flat surface at right angle to the axis of Looper Shaft.

To adjust :

Loosen Screw ❶ and turn Looper ❷.

■How to use Gauge ❸ (Fig. 44)

As shown in Fig.44, fit Gauge ❸ snugly in the slot of the Cylinder, and align the top edge of Looper to that of Gauge ❸.

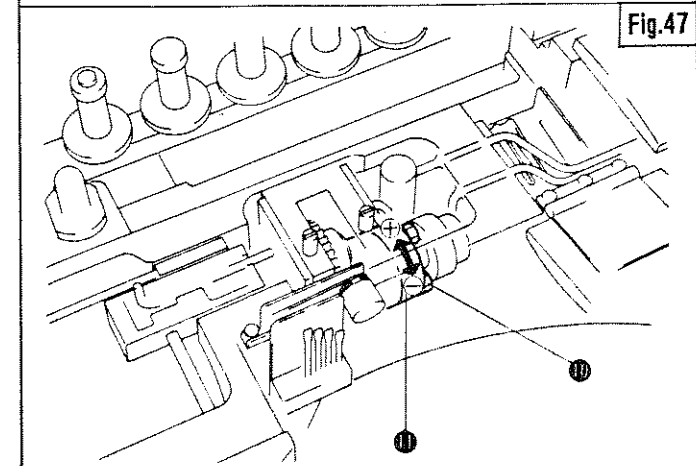
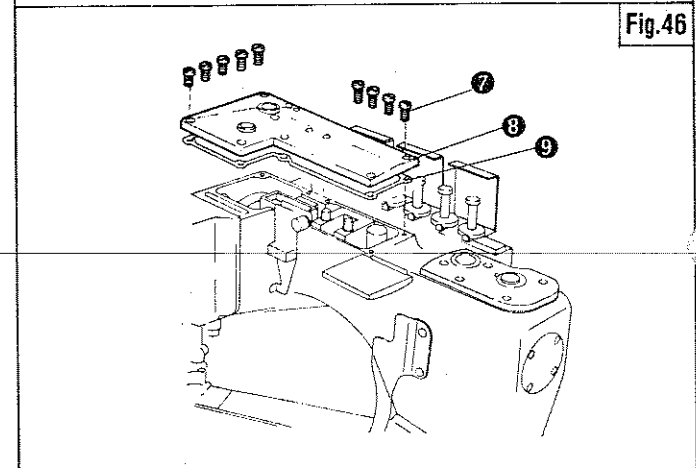
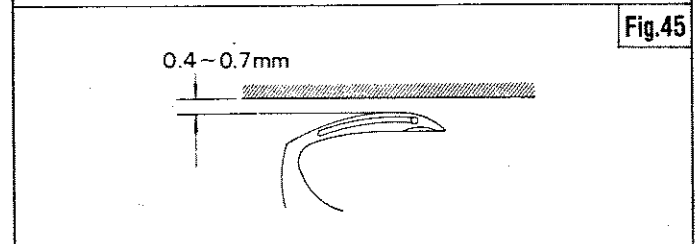
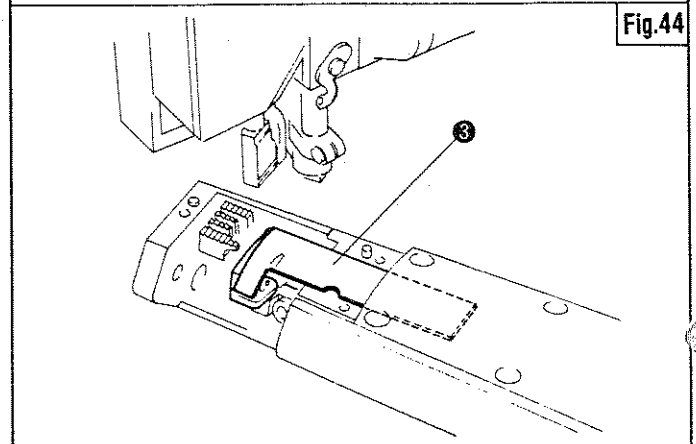
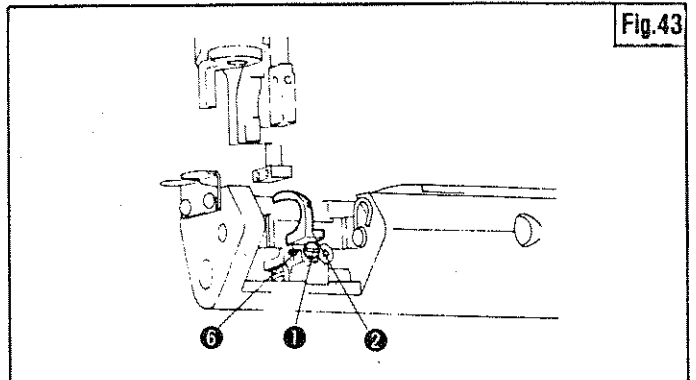

LOOPER HEIGHT ADJUSTMENT(Figs. 43 and 45)

When Looper comes right under Needle Plate, there should be a clearance of 0.4~0.7mm between the top of Looper and the underside of Needle Plate.

To adjust :

Loosen Screw ❶ and turn Screw ❷.

- Use a feeler gauge to measure.

NEEDLE AND LOOPER STROKE SYNCHRONIZATION

❶ Removing the parts(Fig. 46)

Refer to Fig.46, and remove ❷, ❸ and ❹ in sequence.

❷ Synchronizing Needle and Looper stroke (Fig. 47)

Even if Pulley is driven either in forward or reverse, when Needle Bar comes 4.0mm above the lower dead point, the Looper point should assume the same position with respect to Needle.

To adjust :

Loosen Screw ❶, then turn ❷ until the center mark of Timing Collar lines up to the mark on Arm Shaft Drive Belt Pulley.

Turning ❷ in the ⊕ direction makes Looper be advanced against Needle, and turning ❷ in the ⊖ direction makes Looper be retarded against Needle.

- Note that this adjustment must be executed after Needle Bar has been adjusted to a correct position.

■ How to use Gauge (Figs. 48 and 49)

- (1) Lower Needle Bar to the lower dead point, and install Gauge ② with Thumb Screw ① as shown in Fig.48.
- (2) Turn Adjusting Screw ③ on Gauge ② so that a clearance of 4.0mm is achieved between the top of Needle Bar and the bottom of Adjusting Screw ③.
 - A convenient way of adjustment is to use the 4.0mm width of Needle Bar Height Adjusting Gauge ④.
- (3) Attach Bracket ⑤ and Gauge ⑥ to Loper as shown in Fig.49.
- (4) Adjust timing between Needle and Loper stroke so that even if the pulley is driven either in forward or reverse, the point of Gauge assumes the same position as shown in Fig.48.
To adjust :
Loosen Screw ⑩, and turn Coupling ⑪.

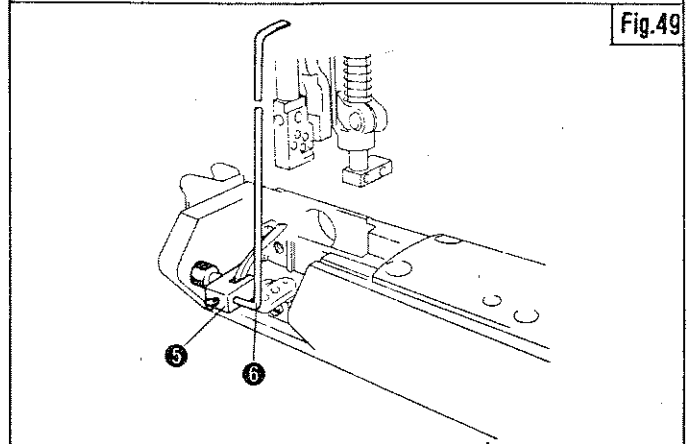
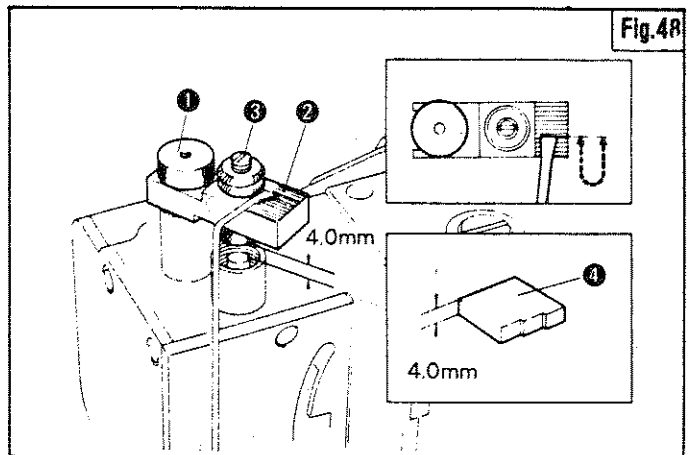

ADJUSTING DISTANCE BETWEEN NEEDLE AND LOOPER (Figs. 50 and 51)

The distance between the centerline of the left Needle and Loper point should be 4.8mm when Loper is at the left dead point.

To adjust :
Loosen Screw ⑦, and move Loper to the left or right.

■ In the case of using Gauge ⑧, apply it as shown in Fig.50.

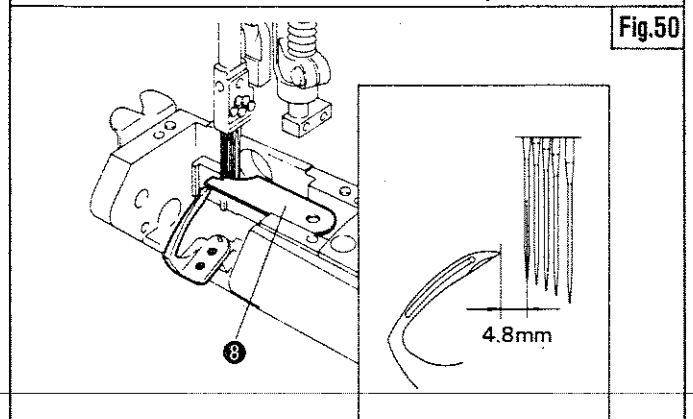

ADJUSTING CLEARANCE BETWEEN NEEDLE AND LOOPER POINT (Figs. 50 and 51)

When Loper passes behind Needles from the left dead point to right, the clearance between Loper point and Needle should be 0mm.

To adjust :
Loosen Screw ⑦, and turn Screw ⑨.

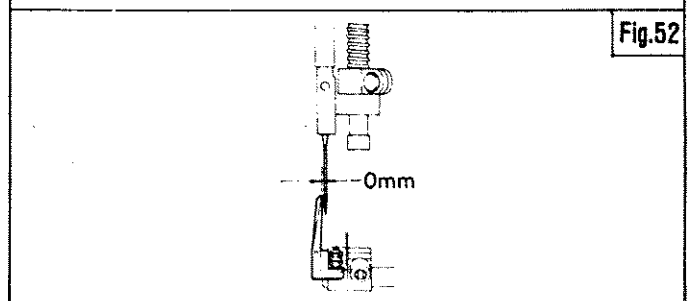
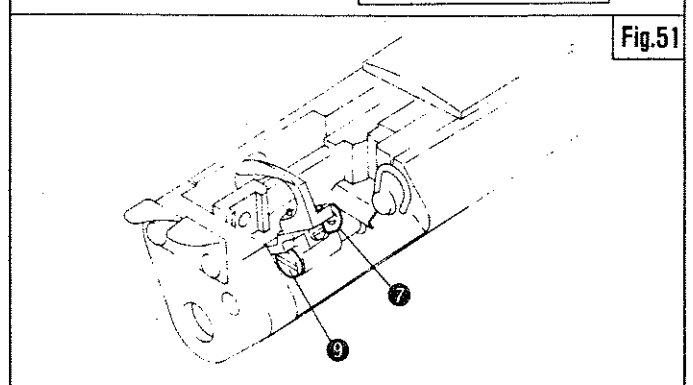

FEED DOG TILT ADJUSTMENT (Fig. 53)

Feed Dog level should be adjusted by loosening Screw ① then turning Eccentric Pin ②. Normally Eccentric Pin ② should be set to a position where its slot is in a horizontal position.

- When Feed Dog needs to be specially inclined back or forth according to the type of the fabric or the requirements of sewing process, Eccentric Pin ② should be turned to the right to incline Feed Dog to the right or vice versa.

FEED DOG HEIGHT ADJUSTMENT (Fig.53)

Standard height of Main Feed is 1.0~1.2mm above the surface of Needle Plate at its far back tooth when Feeds are highest.

Height of Differential Feed Dog should be adjusted in compliance with that of Main Feed Dog. To do this, loosen Screws ③ and ④, then move Feed Dog to the correct height.

NEEDLE GUARD ADJUSTMENT (Fig. 54)

When Looper point reaches the centerline of the left Needle, the clearance between Needle and Needle Guard should be 0.05~0.08mm.

To adjust :

Loosen Screw ⑤.

NEEDLE THREAD GUARD ADJUSTMENT (Fig. 55)

There should be no clearance (0mm) between Thread Guard ⑥ and the left Needle.

To adjust :

Loosen Screws ⑦ and ⑧.

- Note that Needle Thread Guard ⑥ should not be pressed heavily against Needle. Otherwise Needle could be broken.

STITCH LENGTH ADJUSTMENT (Fig. 56)

To adjust stitch length, remove Screw ⑨, loosen Screw ⑩ and move ⑪ up or down.

- Move ⑪ up for a longer stitch, and move ⑪ down for a shorter stitch.
- This adjustment should be followed by the adjustment of Needle Guard provided on Main Feed Dog.

Note that since Needle Guard is provided on Main Feed Dog changing the stitch length (i.e., the number of stitches per inch) causes the clearance between Needle and Needle Guard to vary.

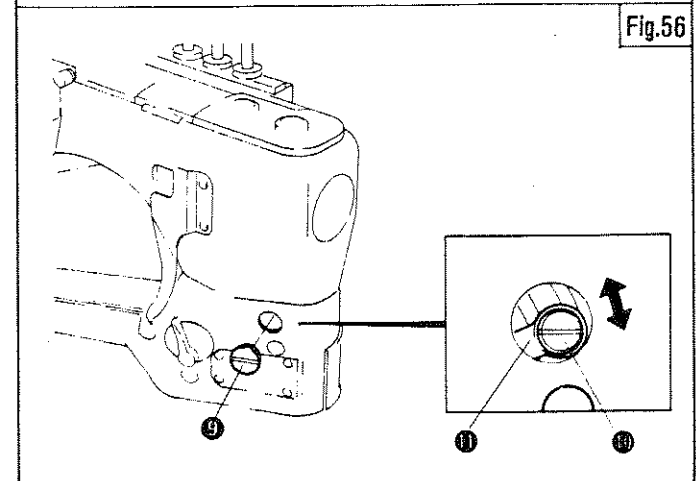
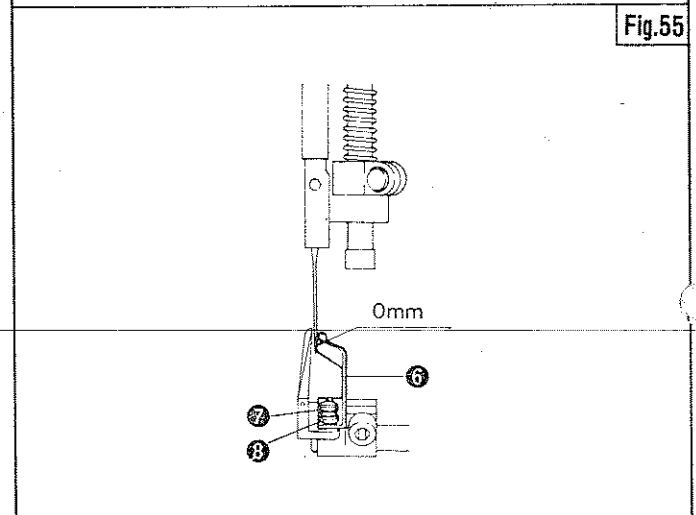
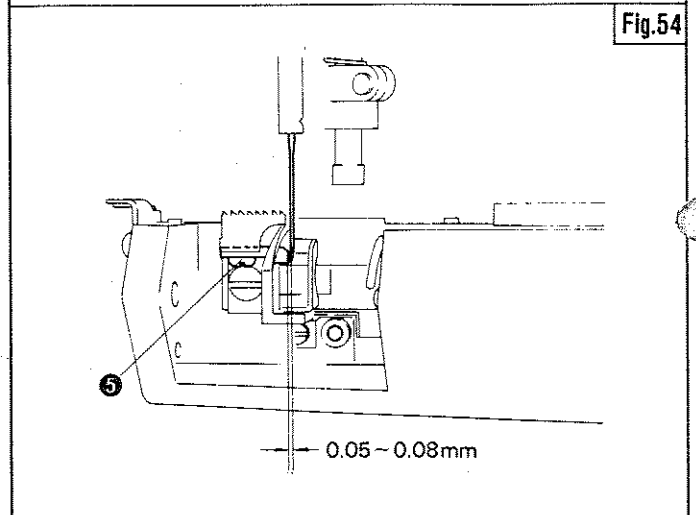
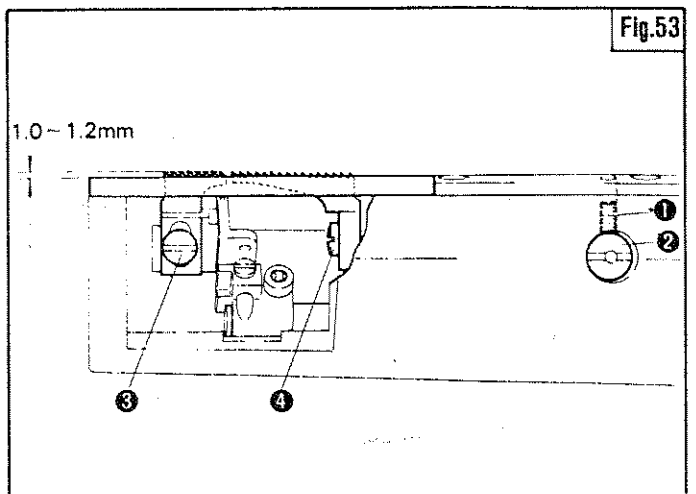

DIFFERENTIAL FEED RATIO ADJUSTMENT(Fig. 57)

Differential feed ratio is adjusted by moving ❶ to right or left.

- Moving ❶ to the right in the order of numbers (5, 6, 7, 8, 9) on the graticule will increase differential feed ratio to gather the fabric.
- Placing ❶ between the graduations 4 and 5 will set differential feed ratio to "0".
- Moving ❶ to left in the reverse order of numbers (4, 3, 2, 1) will decrease differential feed ratio to stretch the fabric.
- Screw ❷ is used to clamp ❶ or limit the motion of ❶ to a specific range.

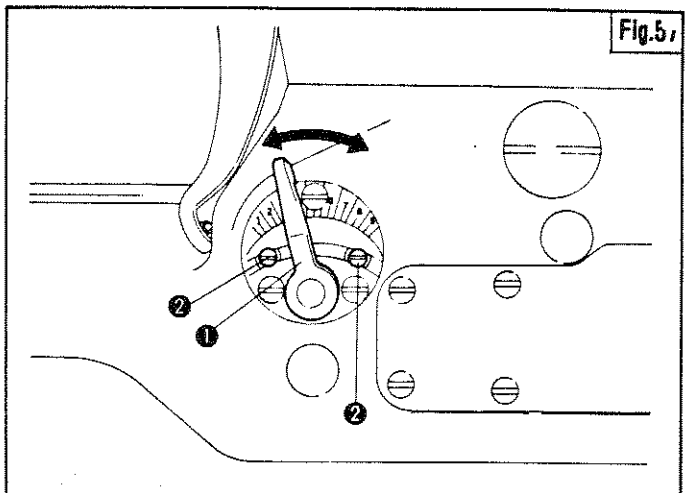

PRESSER FOOT INTERCHANGE(Figs.58, 59 and 60)

Refer to Figs. 58, 59 and 60 and remove ❸~❹ in sequence.

- Screws marked with an asterisk (*) should not be removed but loosened to such an extent that the part secured by it can be removed.
- ❹ in Fig.60 should not be removed but lifted to a position where Presser Foot ❺ can be removed.
- To remove Presser Foot, Needle Bar should be lifted to the upper dead point.

Presser foot installation(Figs. 58, 59 and 60)

Refer to Figs.58 and 59, and follow the reverse order of the removal.

- Presser Foot should be installed in pallel with Feed Dog.
- Please note that wrong setting of Presser Foot may spoil the adjustment of Carrier or Hook (see page 18).
- When installing ❶, be sure to check to see that Presser Foot is not jerky sideways and that it moves up and down lightly before tightening Screw ❷.

Turn Thumb Screw ❸ and check to see that the bottom of Presser Foot is completely pressed against Needle Plate by Presser Foot Spring before tightening Screw ❹.

- For the method of installing Knife, refer to "Knife Interchange" on page 8.

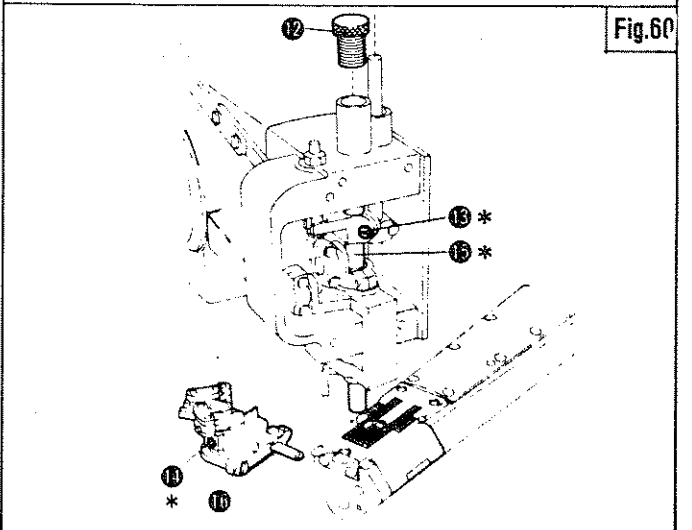
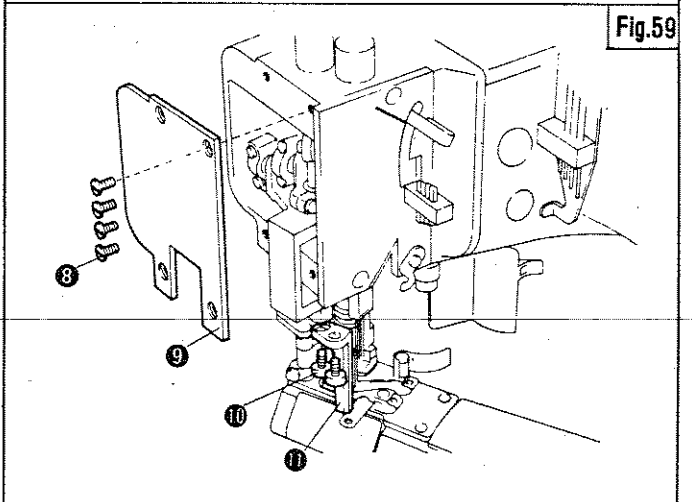
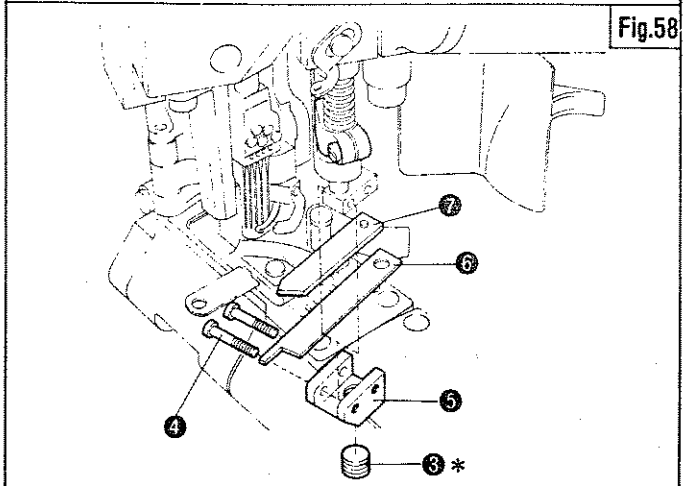

CLEARANCE BETWEEN SPREADER AND NEEDLE HOLDER (Fig. 61)

There should be a clearance of 0.4mm between the connection of Spreader Link and Needle Holder when they come closest to each other by rotating pulley clockwise.

To adjust :

Loosen Screw ① and move ②.

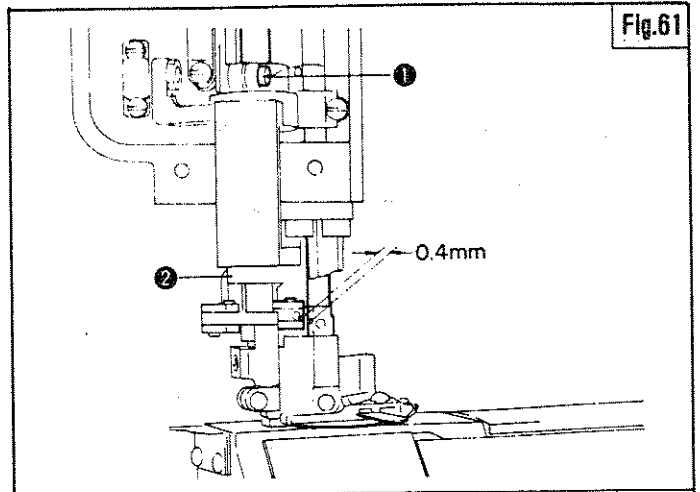

CARRIER AND HOOK ADJUSTMENT (Fig. 62, 63 and 64)

1 Carrier adjustment (Figs. 62 and 63)

The point A of Carrier ③ should be at the center between the left two Needles when Carrier ③ comes to the left extreme.

To adjust :

Loosen Screw ④.

2 Hook adjustment (Figs. 62 and 64)

There should be a clearance of 0.4~0.7mm between ⑤ and ③ when they come closest to each other during a revolution of Pulley.

To adjust :

Loosen Screw ⑥.

3 Fine adjustment

Perform threading for fine adjustment.

Loosen Screw ④ and locate Carrier ③ such that the left two Needles enter a thread loop made behind ③ when ③ comes to the left.

Loosen Screw ⑥ and locate Hook ⑤ such that the lowering right two Needles enter a thread loop made behind Hook ⑤ when ⑤ is moved to the right by turning Pulley.

- Note that if one of Needles pierces the thread loop or if the retainer needle hooks the loop, normal stitches will not be achieved.
- If normal stitches are not achieved, check to see if thread tensions (page 8) and timing of Needle Thread Takeup (page 20) have been maladjusted or if Hook point has worn down.
- Be absolutely sure not to bend or regrind Hook.

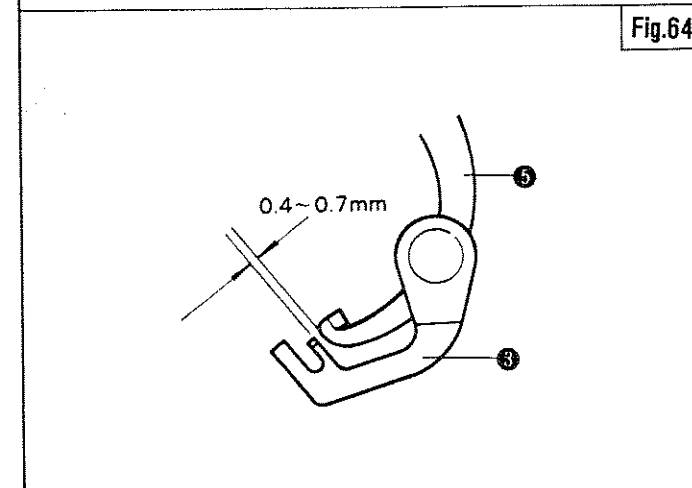
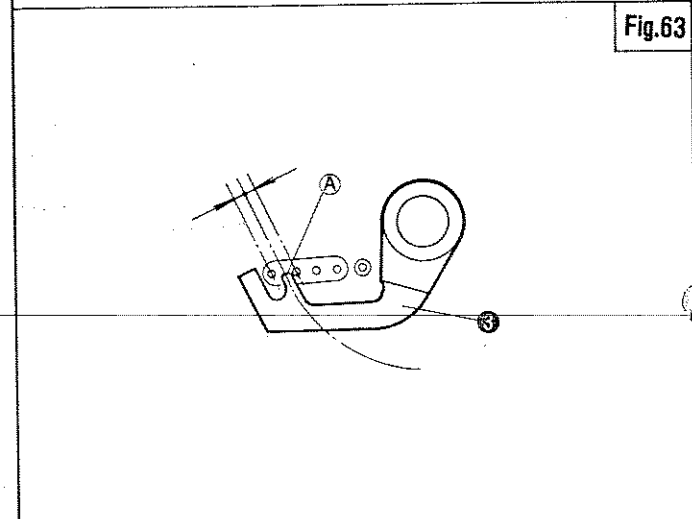
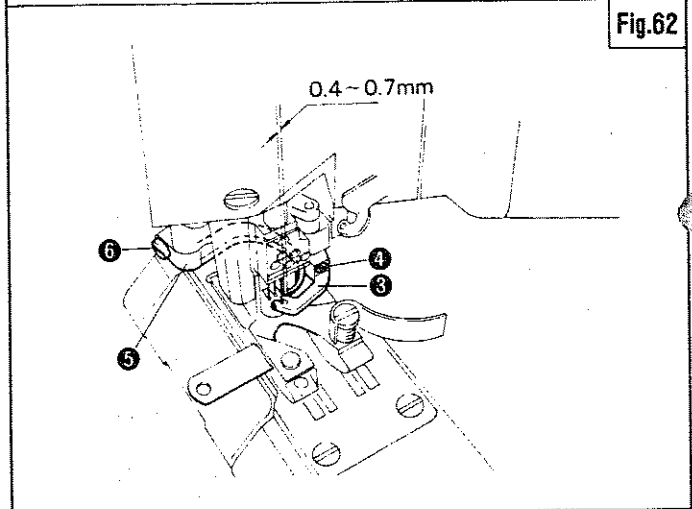

NEEDLE THREAD GUIDE (SMALL) ADJUSTMENT (Fig. 65)

Each Needle Thread Guide should be installed in the correct position with respect to the height of the thread running through Thread Takeup ① in the lower dead point.

- (1) Install Guides ② and ③ at the same height as the needle thread.
 - (2) Install Guide ④ 1.6mm above Guides ② and ③, and Guide ⑤ 3.2mm above ② and ③.
- Each of these Guides functions to keep Needle Thread taut after Needle Thread has left Looper and to provide a good thread loop to be taken up by Looper. Needle Thread Guides can be individually positioned for four Needle Threads so they should be adjusted according to the type of the threads used.

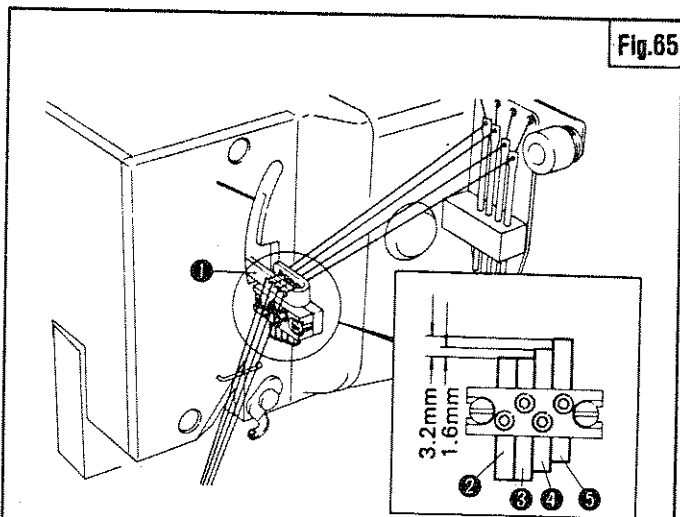

Fig.65

NEEDLE THREAD GUIDE (LARGE) ADJUSTMENT (Fig. 66)

- (1) Install ⑥ and ⑦ 12.7mm down the top of ⑩.
 - (2) Install ⑧ and ⑨ a little higher than ⑥ and ⑦ respectively.
- These Thread Guides should be positioned such that Needle Threads can correctly leave Looper. They should be adjusted to suitable positions according to the types of the threads used.

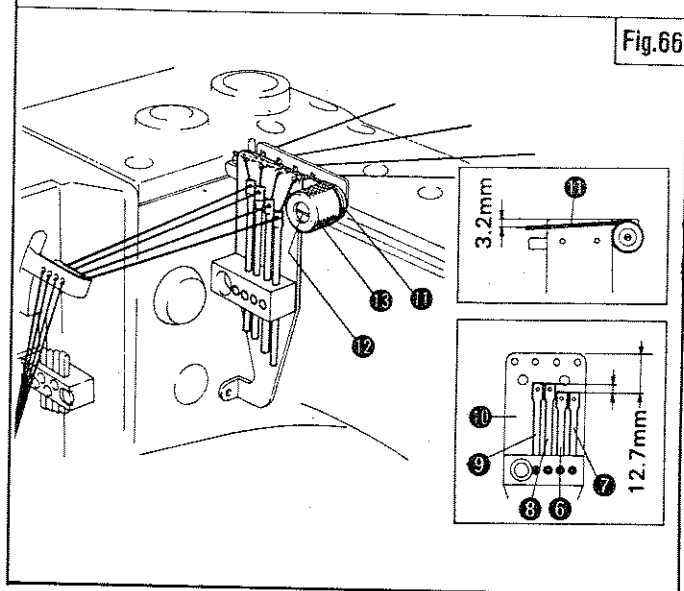

Fig.66

PRESSER BAR POST SPRING ADJUSTMENT (Fig. 66)

Set Spring ⑪ 3.2mm down the horizontal line.
To adjust :

Loosen Screw ⑫ and turn Knob ⑬.

- If the fabric needs to be removed from Presser Foot during sewing, Pulley should be turned in reverse. At this point, Spring ⑪ functions to prevent a thread loop from being made on the front of Needle.

INSTALLATION POSITION OF SPREADER THREAD GUIDE (Fig. 67)

Hold the underside point of ⑭ 2.4mm above Bracket.

To adjust :

Loosen Screw ⑮ and move ⑭ up or down.

- The height of ⑮ determines the amount of Spreader Thread in the seam so it should be adjusted for the type of thread used and other factors.

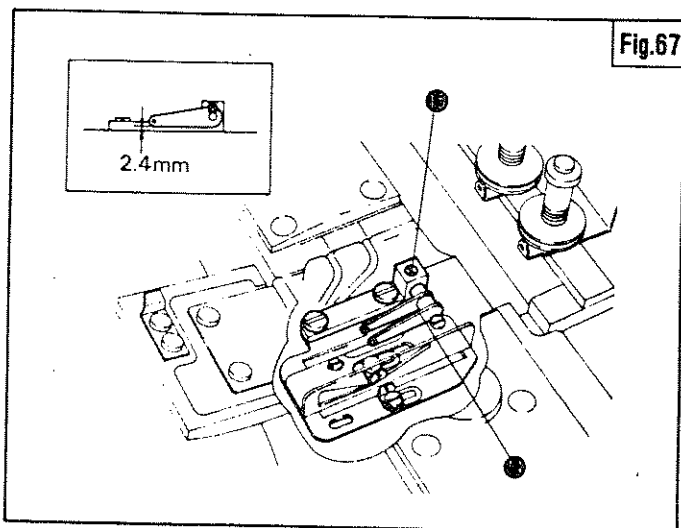

Fig.67

SPREADER THREAD TAKEUP ADJUSTMENT(Fig.68)

Spreader Thread Takeup should be adjusted so that Spreader Thread is released from point (a) of ① and is fed before Needle Bar begins to move up.

To adjust :

Loosen Screw ② and turn ①.

- ① should be installed so that Stop Screw ③ comes in the center of the ring opening as shown in Fig.68.
- ① and ⑬ (page 19) should be adjusted so that Spreader Thread is cast off between the time when the thread is traversed by the action of Spreader Thread Hook and the time when Needle Bar begins to move up.
- If the above timing should not be achieved, Spreader Thread remains taut, thereby precluding the formation of the left needle thread loop.

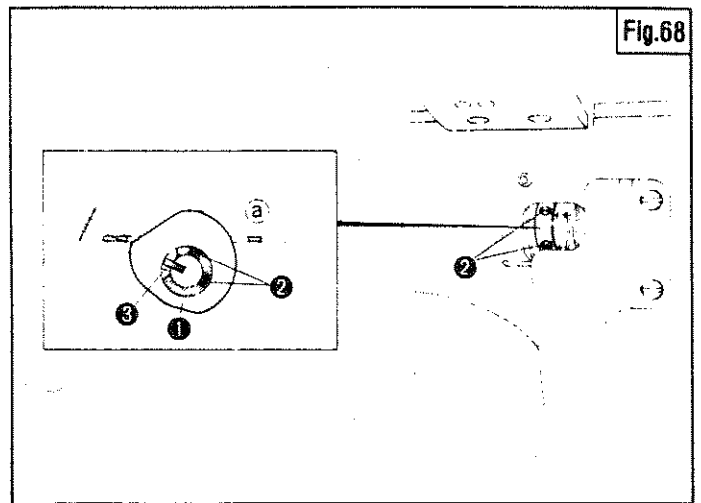

Fig.68

LOOPER THREAD(Fig. 69)

Tighten the screw ⑥ at lowest position for the thread guide ④.

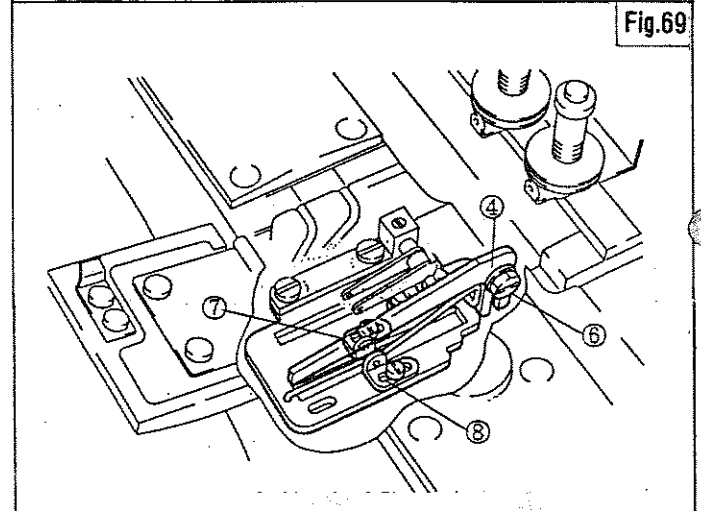

Fig.69

SETTING LOOPER THREAD EYELETS (Fig. 69)

Install the thread guide ⑦, ⑧ at center of oval slot.

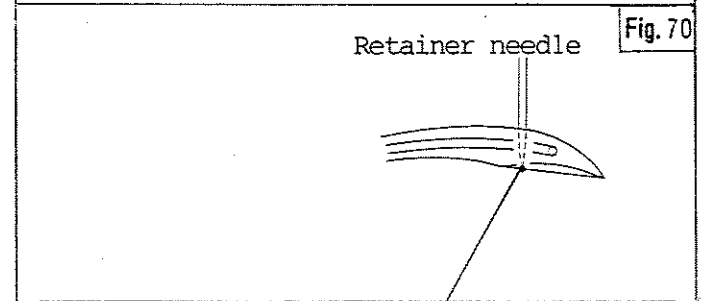

Fig.70

LOOPER THREAD TAKEUP ADJUSTMENT(Fig. 70)

Adjust as the looper thread come off the thread take-up, when the tip of the retainer needle positioned to the lower face of looper as figure.

To adjust :

Loosen Screw ⑪ and turn ⑩.

- As shown in Fig.70, ⑩ should be installed so that Stop Screw ⑫ comes to the center of the ring opening.

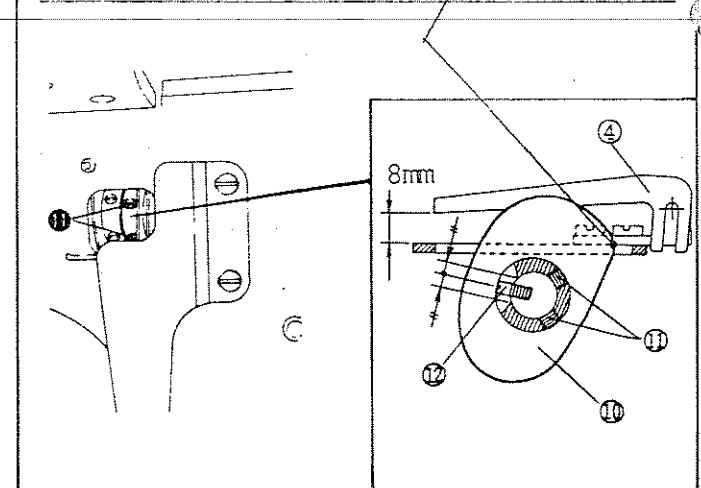

ADJUSTING THE FABRIC GUIDE (Fig. 71)

1. Back and forth position

Bracket **(A)** should touch the edge **(B)** of the needle plate.

The tip of Fabric Guide **(1)** should not touch Presser Foot Finger **(2)** when the presser foot is raised.

To adjust, loosen Screws **(3)**.

2. Right and left position

The right and left position of Fabric Guide **(1)** regulates the overlap of the upper ply against the lower ply.

To increase the overlap, move the tip in the \oplus direction.

To adjust, loosen Screws **(3)**.

- When Fabric Guide **(1)** is not used, shift it in the arrowed direction.

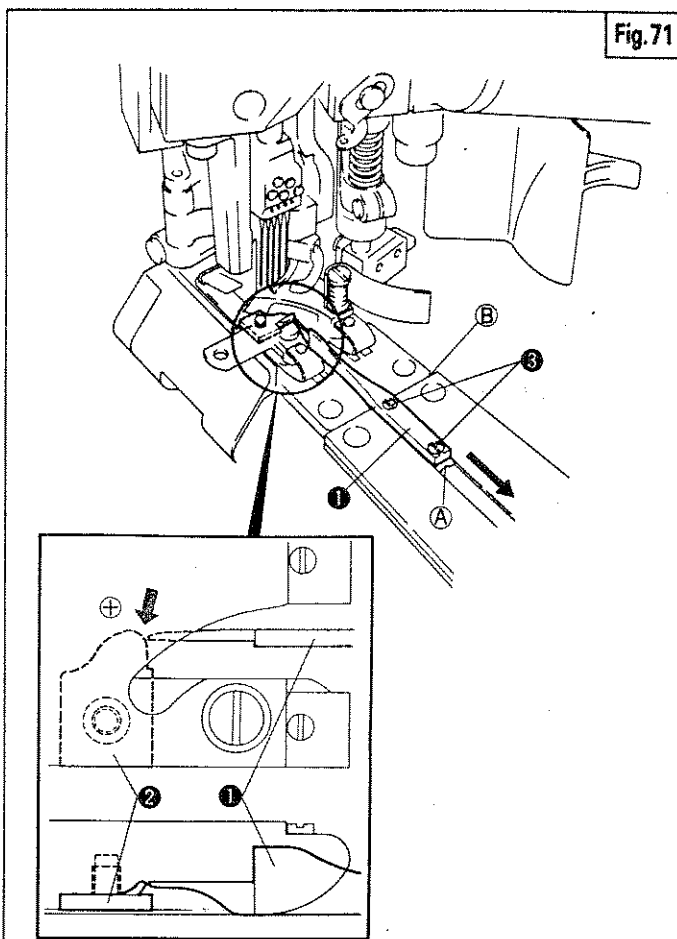

Fig.71

GAUGE PARTS (1)

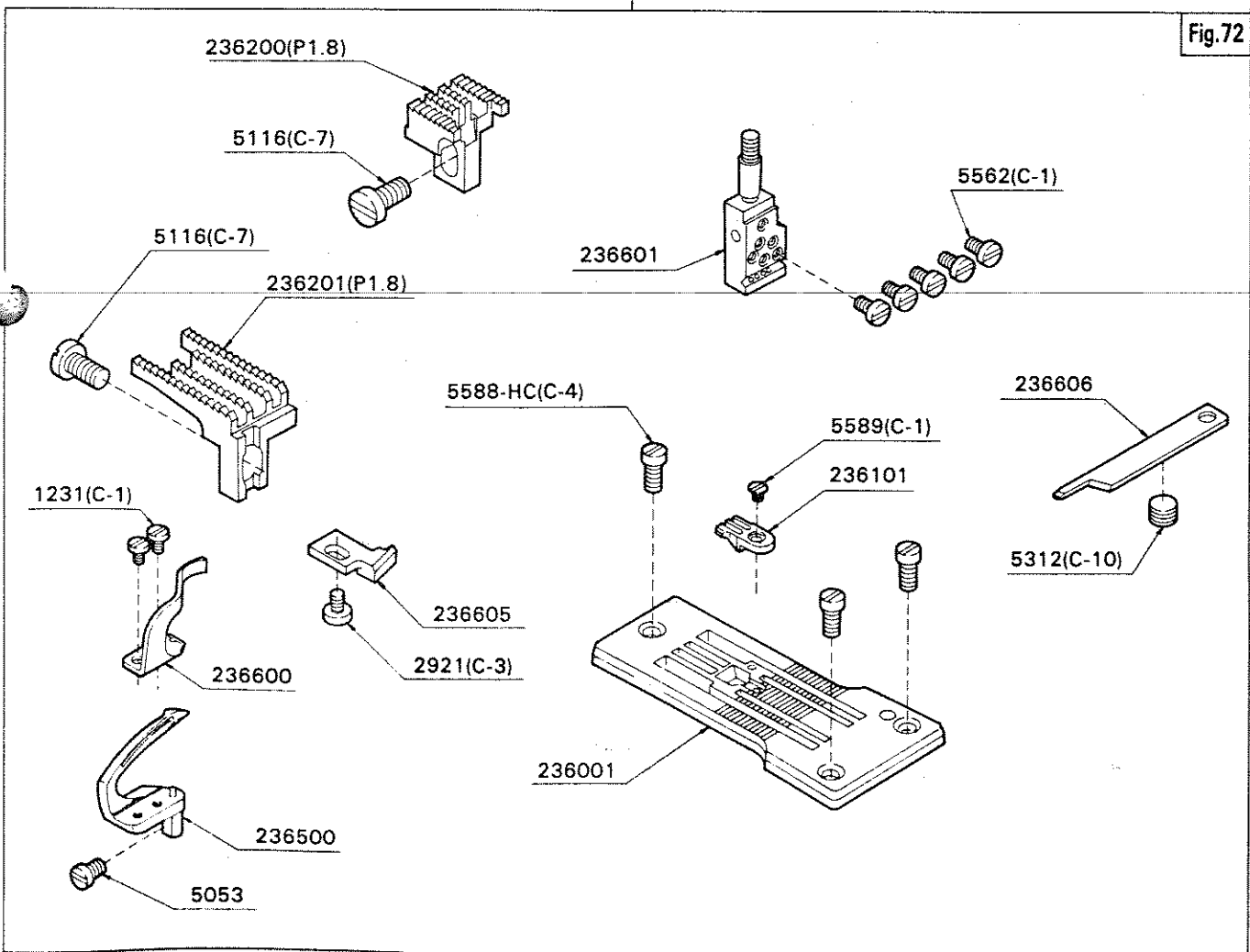
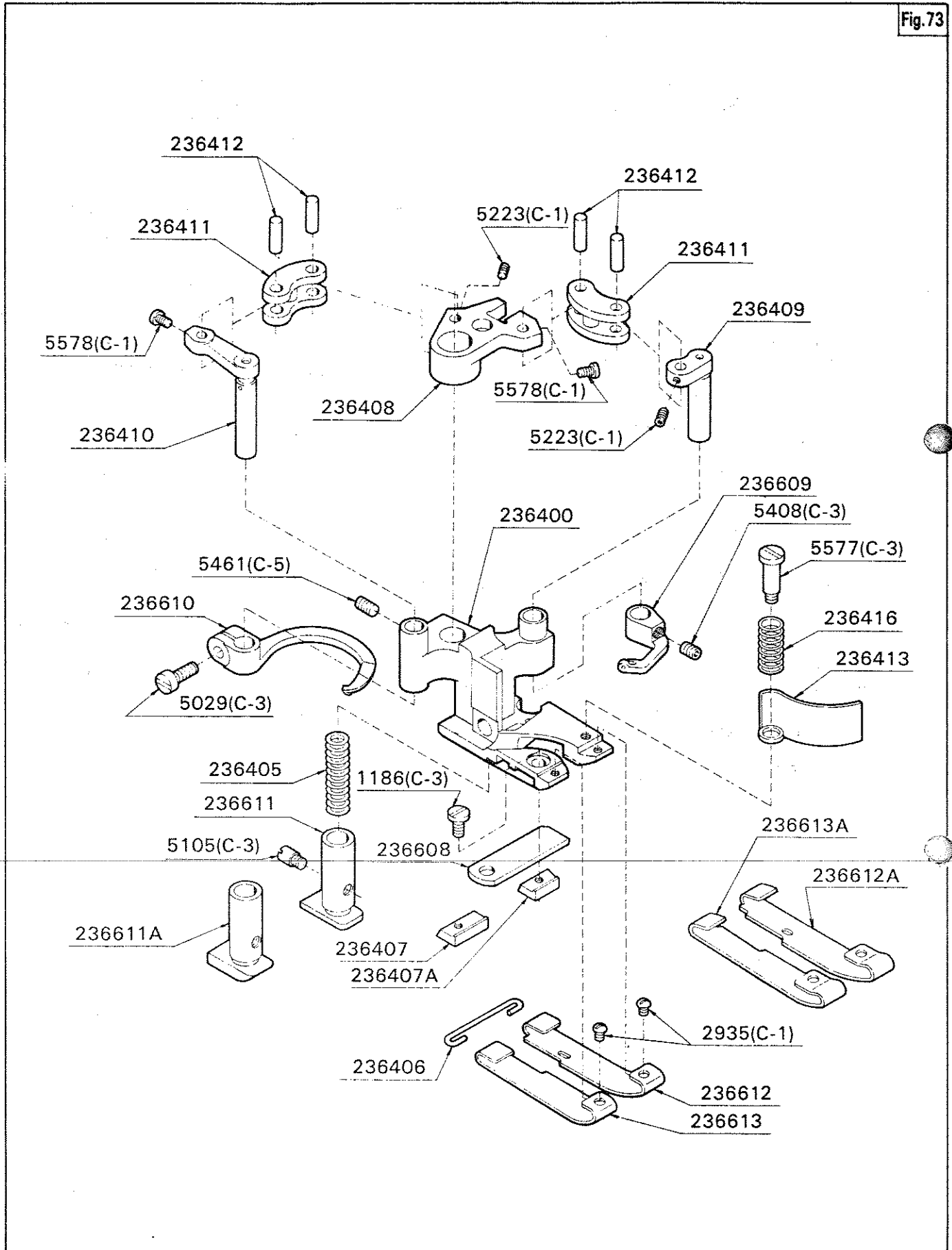
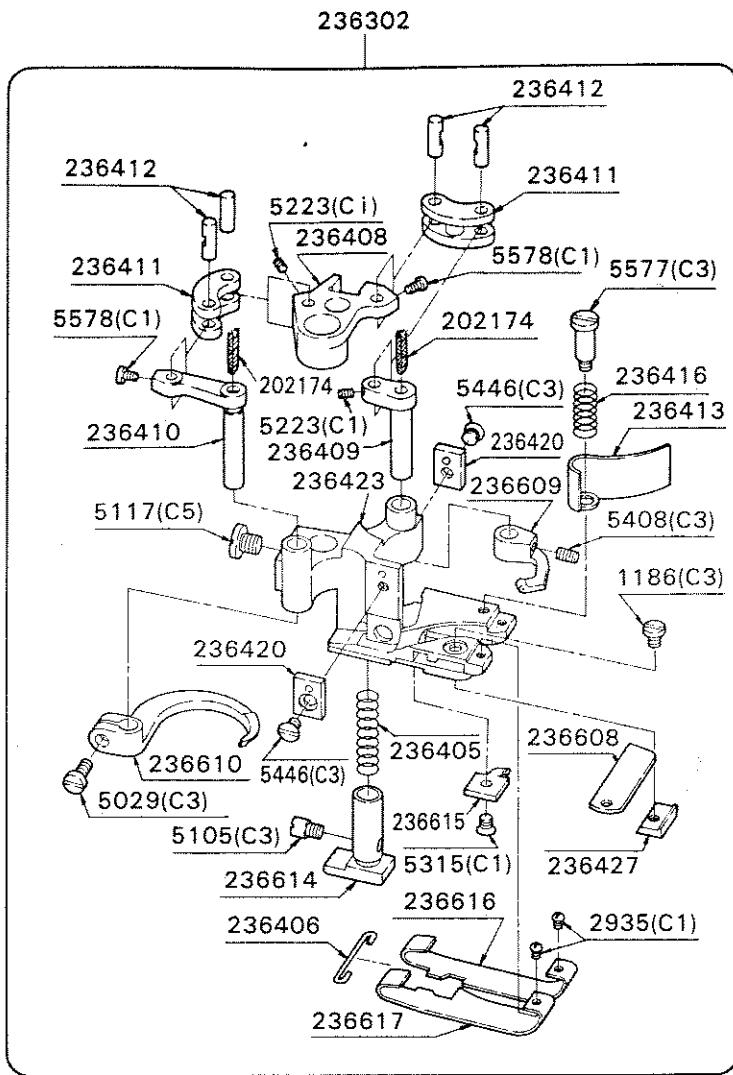
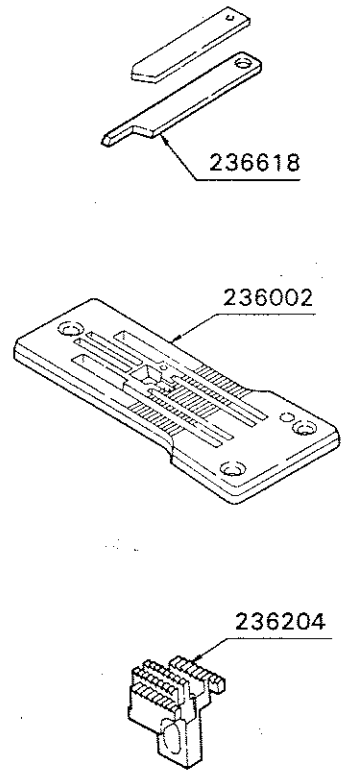

Fig.72





ゲージパーツ
GAUGE PARTS



FS603

専用部品
SPECIFIC PARTS

